



Electrical Conductivity Sensor **EC3000 User Manual**

Version 1.1

EC3000 User Manual

Table of Contents

Table of Contents	2
1 Introduction	5
1.1 System Description.....	5
1.2 How to Use the Manual.....	5
1.3 Certification.....	6
1.4 Unpacking and Inspection.....	6
1.5 Serial Number.....	6
1.6 Warranty Policy.....	6
1.7 Factory Service & Repair.....	7
1.8 Contact Details.....	8
2 Sensor Overview	9
2.1 Theory of Measurement.....	9
2.1.1 Toroidal Sensing Head.....	9
2.1.2 Temperature.....	10
2.1.3 Normalisation.....	10
2.2 Applications.....	10
2.3 Instrument Details.....	10
2.3.1 Sensor Design.....	10
2.4 Cable Details.....	11
2.4.1 Mechanical Specifications.....	11
2.5 Options and Accessories.....	12
2.5.1 Sensor Shroud.....	12
2.5.2 Sensor Body.....	12
2.5.3 Cable Options (inc. Detachable Cables).....	12
2.5.4 Communication Cables.....	12
2.5.5 Optional Serial Output – SDI Adapter Unit.....	12
2.5.6 On Board Battery Housing.....	13
2.6 Battery Replacement.....	14
2.6.1 Important Battery Information.....	14
2.6.2 Battery Warnings:.....	14
2.7 Sensor Factory Calibration.....	16
3 Sensor Operation	17
3.1 Wiring & Connections.....	17
3.2 Software Setup.....	19
3.2.1 Direct Link.....	19

3.2.2	SmartCom	19
3.2.3	Properties	24
3.2.4	Channels	24
3.2.5	External Battery: (Solar Battery).....	24
3.2.6	Internal Battery: (Battery Pack)	25
3.2.7	Battery Life & Memory Calculator.....	25
3.2.8	Temperature	26
3.2.9	EC Raw	26
3.2.10	EC Norm.....	26
3.2.11	Salinity	27
3.2.12	Schedules.....	27
3.2.13	Add New Schedule (Wizard)	28
3.2.14	Add New Schedule – Final Screen.....	30
3.2.15	Averaging	30
3.2.16	Data Variation (Event Based Logging).....	30
3.2.17	User Calibration Screens	31
3.2.18	Clear Memory Tab.....	31
3.2.19	Set Clock.....	32
3.2.20	PC Clock.....	32
3.2.21	Manual Entry Clock	32
3.2.22	Start Logger.....	33
3.2.23	Collect Data	34
3.2.24	Aquagraph – Tabular View.....	35
3.2.25	Aquagraph – Graphical View.....	35
3.2.26	Aquagraph – Tools & Options	35
3.3	Quick Check and Re-Calibration	36
3.3.1	Quick check.....	36
3.3.2	Re-Calibration using the loop calibrator	36
3.3.3	Re-Calibration Method Using Calibration Solutions	37
3.4	Installation	37
3.4.1	Field Deployment Considerations	37
3.4.2	Cabling Considerations	38
3.4.3	Typical Sensor Installations.....	38
	Field Installation must ensure	38
3.4.4	Other Considerations	38
3.4.5	Guidelines for cleaning equipment.....	39
4	Appendix A -Additional Information	40
4.1	Specifications	40

4.2	<i>Quick Start Guide – EC3000 Electrical Conductivity Sensor</i>	41
4.3	<i>Example – Certificate of Conformance</i>	42
4.4	<i>Engineering Note – Detachable Cables</i>	43

I Introduction

1.1 System Description

Thank you for purchasing the Greenspan Conductivity Sensor Model EC3000. This manual provides a guide to the configuration, operation and maintenance of the sensor to provide long term reliable and accurate monitoring.

The Greenspan EC3000 is a fully submersible self-contained Conductivity Measurement Sensor and Data Logger, designed for remote applications. It utilises a sophisticated Toroidal Measurement technique and digital signal processing to provide fully calibrated reliable and stable long-term measurements.

Conductivity and temperature are two of the most common water-related parameters measured by scientists and engineers for assessment and research purposes. Field conductivity measurements in ionised solutions have traditionally been fraught with inaccuracy due to temperature and electrode effects. The Greenspan Electrical Conductivity (EC) Sensor substantially eliminates these conventional sources of error by utilising a unique combination of advanced features including:

- Toroidal sensing technology
- On-board temperature measurement
- Microprocessor Temperature compensation and linearisation
- Internal High Capacity Data Logger

Designed for low power consumption, the sensor can be operated from remote power sources for extended periods. The sensors are suitable for use in harsh remote applications including groundwater, salty or acidic water conditions.

The Sensor is packaged in an Acetal (Black Delrin) tube, with Double O ring connections for the cable and sensor head. This fully submersible sensor design is rugged and well proven and can withstand the harsh conditions found in remote field applications. An optional on-board battery housing provides for a complete stand-alone remote monitoring sensor.

1.2 How to Use the Manual

Along with this manual, there are several other documents that may assist in the successful configuration and operation of the Greenspan EC3000 Sensor. These should be maintained on file as a permanent reference as to the features, applications and use of the EC3000.

Greenspan EC3000 – Specifications Brochure

Greenspan EC3000 – Certificate of Conformance

Greenspan EC3000 – Quick Start Guide

1.3 Certification

The EC probes are assembled and tested in accordance with Greenspan's ISO 9001 Quality Certified System. Each Sensor is individually manufactured and certified against a traceable Standard ([See Section 2.7](#))

Following calibration the sensors undergo a range of additional control processes to ensure that all specifications are consistent and documented.

- ***The instrument is visually inspected, marked and labelled.***
- ***The complete sensor calibration record is archived for reference, and batch number information is kept on file for statistical analysis.***
- ***An individual Certificate of Conformance is issued to the customer.***

1.4 Unpacking and Inspection

All Greenspan Analytical Sensors are made to order and are individually calibrated and inspected. This ensures that they leave the factory in a working condition. They are packed in new cartons for shipping. On receipt, the customer should inspect the packaging and contents for any signs of damage during transportation. The customer should also check that all items on the delivery note have been received.

Please contact the factory in case anything has been damaged or missing. A full set of documentation including Certificate of Conformance, Quick Start Guide, and Full Operator Manual will be provided with all equipment – either in hard copy format or in electronic format on the CD shipped with the goods.

If fitted with a 316 Stainless Steel body, the unit should only be used in low EC situations. Care should be taken against possible corrosion in high Chloride or Ferric solutions, water with high iron or sulphate reducing bacteria, or low dissolved oxygen. The Sensor can be fitted with an Acetal body which provides superior corrosion protection in a wide range of chemically active waters.

Because an individual sensor may be used in a variety of locations, media compatibility should be checked before installing and advice sought from Greenspan if any doubt exists.

1.5 Serial Number

Checking the Model Number and Range

Before installing your Greenspan EC3000 sensor check the information on the label is correct to confirm you have received the instrument you have ordered. The label will look similar to this.

MODEL	EC3000
RANGE	0 – xxxx µS/cm
S/N	012345

The customer is advised to keep a record of the serial numbers in case the sensor is lost or the label damaged. Greenspan Analytical keeps records of all sensors sold including a calibration history.

1.6 Warranty Policy

Greenspan Analytical warrants all new Greenspan products against defects in materials and workmanship for **12 months** from the date of invoice.

Products that prove to be defective during the warranty period will be repaired or replaced at the discretion of Greenspan Analytical.

Under Greenspan Analytical warranty conditions; it is the responsibility of the customer to cover shipping charges back to the factory. Upon repair/replacement Greenspan Analytical will cover the return shipping charges to the customer.

This warranty does not apply to products or parts thereof which have been altered or repaired outside of the Greenspan Analytical factory or other authorised service centre; or products damaged by improper installation or application, or subjected to misuse, abuse neglect or accident. This warranty also excludes items such as reference electrodes and Dissolved Oxygen membranes that may degrade during normal use.

Greenspan Analytical will not be liable for any incidental or consequential damage or expense incurred by the user due to partial or incomplete operability of its products for any reason whatsoever or due to inaccurate information generated by its products.

All Warranty service will be completed as soon possible. If delays are unavoidable customers will be contacted immediately.

Any sensor should not be dismantled unless under instruction from Greenspan Analytical Technical Service staff. Incorrect handling will void the warranty.

1.7 Factory Service & Repair

The correct choice of sensor and assistance with field installation can be provided by Greenspan and their sales offices. A correct choice of equipment, together with technical advice and field experience should result in long-term success in the field. **Greenspan Technical Services** is dedicated to customer support and provides assistance in the selection, installation, deployment and commissioning of sensors with a full range of consulting services. All Greenspan products are designed, developed and manufactured in Australia and can be supplied at short notice.

If for some reason sensors are required to be returned to our factory or your sales representative, please note the model no. and serial no., describe the problem, including how and under what conditions the instrument was being used at the time of malfunction. Clean the product and the cable. Decontaminate thoroughly if used in a toxic or hazardous environment. Carefully pack product in original packaging if possible & include a statement certifying product and cable have been decontaminated with supporting information. Products returned for repair must be accompanied by a completed GRA (Goods Return Advice) form. All sensors returned for service and repair work must be properly decontaminated prior to return. A cleaning charge may be applied to sensors that require further decontamination. Service work will not commence until the quotation has been accepted by the customer. A purchase order for all repair and service work will be required before work is carried out.

1.8 Contact Details

Australia

Head Office
Goyen Controls Co Pty Ltd
268 Milperra Road
Milperra, NSW 2214

Telephone: 1800 805 372
Facsimile: 1300 658 799

Sales and Service

**Queensland, South Australia
Victoria, Western Australia**

Telephone: 1800 805 372
Facsimile: 1300 658 799

USA

Goyen Valve Corporation
1195 Airport Road
Lakewood
New Jersey 08701, USA

Telephone: 1 732 364 7800
Facsimile: 1 732 364 1356

Asia

Goyen Controls Co Pty Ltd
Shanghai Representative Office
1209 Greenland Business Centre
1258 Yu Yuan Road
Shanghai PC200050, CHINA

Telephone: 86 21 5239 8810
Facsimile: 86 21 5239 8812

Goyen Controls Co Pty Ltd
73-M Jalan Mega Mendung
Kompleks Bandar OUG
58200 Kuala Lumpur, MALAYSIA

Telephone: 60 37 987 6839
Facsimile: 60 37 987 7839

Greenspan Singapore Pte Ltd
02-01, Minwa Industrial Building
39 Genting Lane
Singapore 349554

Telephone: 65 6748 0140
Facsimile: 65 6748 2534

Europe

Goyen Controls Co UK Ltd
Unit 3B Beechwood
Chineham Business Park
Basingstoke, Hampshire, RG24 8WA
UNITED KINGDOM

Telephone: 44 1256 817 800
Facsimile: 44 1256 843 164

Tyco Umwelttechnik GmbH
Im Petersfeld 6
D-65624 Altdenz
GERMANY

Telephone: 49 6432 1001/1002
Facsimile: 49 6432 63810

Mecair S.r.l.
Via per Cinisello 97
20054 Nova Milanese
Milano,
ITALY

Telephone: 39 362 375 118
Facsimile: 39 362 375 124

Address: *Tyco Environmental Systems
Greenspan Analytical Manufacturing Plant
22 Palmerin Street
WARWICK QLD 4370
AUSTRALIA*

Phone: + 61 (0)7 46601888
Fax: + 61 (0)7 46601800

Internet: www.tyco-environmental.com

2 Sensor Overview

2.1 Theory of Measurement

Conductivity is the measurement that indicates the ability of a solution to carry an electric current. It is defined as the inverse of resistance (Ohms) per unit square and is measured in units of Siemens/metre or micro-Siemens/centimetre.

Electrical Conductivity readings are a function of the number of ions present and their mobility. The electrical conductivity of a liquid changes due to the ion mobility being temperature dependant. The temperature co-efficient of conductance (or the K factor) varies for different salts and can be in the range 0.5 to 3.0. A default value of 1.84% per degree Centigrade is used in the EC 3000.

EC is a function of both salt concentration and temperature, and its value can be expressed as non-normalised or normalised. The non-normalised (Raw) reading will vary with temperature even if the concentration of salt in the liquid does not change. Normalisation automatically compensates for temperature variations providing the salt concentration remains the same. Normalisation is referenced to 25°C which means that the raw and normalised readings are identical at this temperature.

The measurement of conductivity is usually carried out to assist in the determination of the salt content of a water body (the salinity). The EC 3000 sensor calculates a salinity value, based on method "2530-D, Algorithm of Practical Salinity" (Standard Methods for the Analysis of Water and Wastewater). This method is also contained in "UNESCO Technical papers in marine science 44 – Algorithms for computation of fundamental properties of seawater."

2.1.1 Toroidal Sensing Head

The EC sensor uses an electromagnetic field for measuring conductivity. The black plastic head contains two ferrite cores configured as transformers within an encapsulated open ended tube. One ferrite core is excited with a 10 KHz sinusoidal voltage which generates an electromagnetic field that surrounds both ferrite cores. The degree of coupling between the cores is inversely proportional to the resistivity of the coupling medium which is the water that fills the tube. An increase in charged ion mobility or concentration causes a decrease in the resistivity and a corresponding increase in the output of the EC sensor.

The main benefit derived from utilising toroidal sensing technology for the measurement of EC is the reduction in fouling and the elimination of system errors caused from electrode degradation. There are no electrodes in direct contact with the water that can foul, erode or corrode. The sensor head should be periodically inspected and cleaned with fresh water and damp cloth. The protective shroud is easily unscrewed from the head for quick access. Bottle brushes are commonly used for cleansing the sensor hole. In marine environments crustaceans may need removal at regular intervals.

The toroidal sensors create a magnetic field around the sensing head. The standard EC sensor includes a shroud around the transducer head that constrains this field and allows the sensor to be deployed close to other objects. The sensor head should always be completely submerged and positioned such that the possibility of air bubbles becoming entrapped within the sensor hole is minimised. Large bubbles may cause errors if trapped.

2.1.2 Temperature

The EC3000 Sensor utilises an internal temperature sensitive device to independently monitor the temperature of the sensor and the sample solution. The sensor provides a temperature output over the range 0-50°C on a separate channel. The signal is also used internally to normalise the EC output to 25°C and temperature compensate other channels over the range 0-50°C. The most accurate temperature reading will be obtained when the entire sensor has been allowed time to stabilise with the body of water in which it is deployed.

2.1.3 Normalisation

In solution with a constant dissolved salt content an un-normalised EC sensor's output changes by 1.84% /°C. The normalised reading automatically produces a result of what the solution conductivity would be at 25°C.

2.2 Applications

Applications in which the Greenspan EC3000 can be used include:

- Monitoring of streams and rivers.
- Monitoring of water storage bodies including stratification studies.
- Intermediate and final effluent treatment monitoring.
- Hydrological run off studies.
- Ground and bore water analysis.
- Drinking water filtration efficiency.
- Industrial process monitoring.
- Sludge and dredge monitoring.

2.3 Instrument Details

2.3.1 Sensor Design

The Greenspan EC Sensor consists of the following primary elements:

- Toroidal sensing head (conductivity sensor)
- Temperature sensor (Temperature Button on EC Head)
- Microprocessor controlled signal conditioning and logging device
- Stainless steel or Acetal Body Material
- Sensor Head Shroud (removable for cleaning)
- Data cable or Battery Pack option

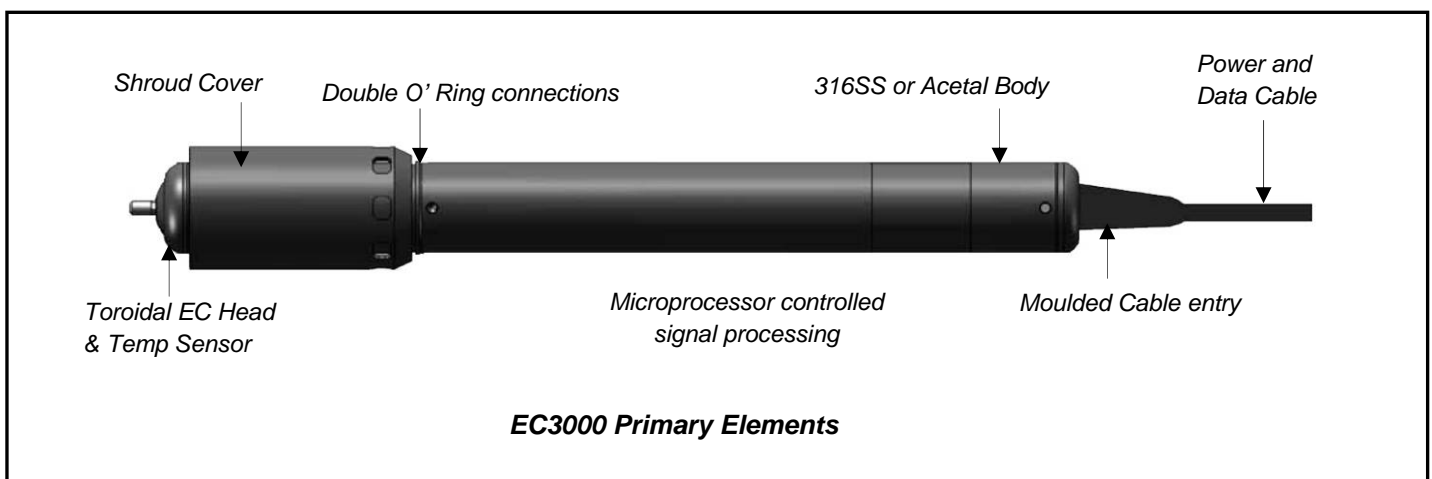

2.4 Cable Details

All Greenspan Sensors utilise a specially designed Polyurethane Cable. The cable contains 12 x conductors, 1 x drain wire, and an internal vent tube. The outer jacket is made from UV stabilized Polyurethane and is suitable for all external, underwater or harsh environment applications. This common cable construction is utilized for vented and non vented sensors and all Greenspan Water Quality Sensors. Cables are generally factory fitted at time of manufacture in specified lengths. Cables can be joined or repaired in the field providing a waterproof connection can be maintained. Alternatively, cables can be terminated in waterproof junction boxes where cabling to other devices or longer cable runs are required.

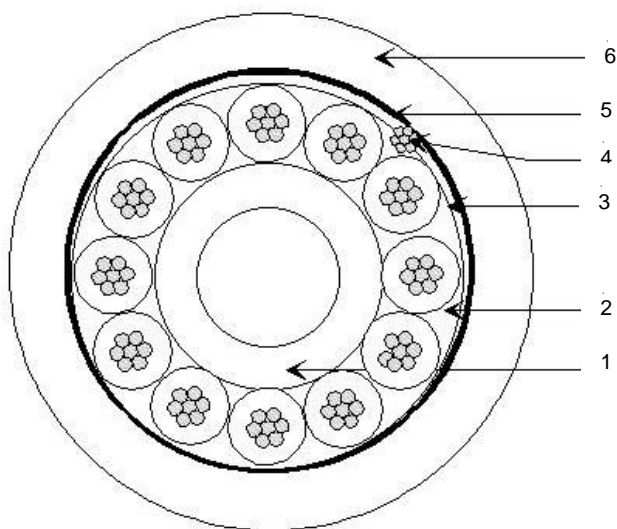

Cable Construction

- 1 – **Vent Tube:** Polyamide
(size ID x OD) 2.40 x 3.20 mm
- 2 - **12 x Conductors**
7 x 0.20 mm Tinned Copper
Section = 0.22mm² AWG24
Insulation : Polypropylene
(size) = 1.10 mm ± 0.05 mm
- 3 - **Tape:** Polyester
- 4 – **Drain Wire:** 7x0.20 TinCu
- 5 - **Tape:** Polyester Aluminium
- 6 - **Jacket:** Polyurethane black,
(size OD) 8.05 mm ± 0.15

2.4.1 Mechanical Specifications

- Specially Manufactured Greenspan Cable with 12 cores and Internal Vent
- High chemical resilience and abrasive resistance
- Conductor cross section : AWG 24,
- Electrical Resistance 9 ohm per 100m (per conductor)
- Operating temperature: 85°C (max.),
- Bending radius (static) : 6 ,
- Bending radius (dynamic) 12.
- Max Operating voltage : 250V
- Jacket Printing (white colour each meter)
- Conductor colour codes : green, yellow, white, black, brown, turquoise, violet, pink, red, blue, grey
- Tensile Strength is sufficient to self suspend the Greenspan Sensor to depths of 300m.
- Long term creep due to temperature effects or tensile loading is negligible.

The moulded cable is fitted to the sensor using a double o ring seal and located using 2 x grub screws. The length of the cable is not critical to the long term calibration and operation of the sensor (provided the electrical requirements such as minimum supply voltage are maintained).

2.5 Options and Accessories

2.5.1 Sensor Shroud

Please note that EC sensors fitted with the protection shroud are calibrated in the factory with the shroud on. If the shroud is removed the calibration in water will be affected. Please ensure that the shroud is always fitted for normal use in water and only removed whilst cleaning. The shroud should be fitted when performing calibration checks in solutions.

If the sensor needs to be deployed without a shroud this requirement should be noted at time of order. The factory can then perform a special calibration without a shroud using large volumes of standard solutions. On deployment it is necessary to maintain a space of at least 100mm (4") around the head.

2.5.2 Sensor Body

Sensor is available with a black Acetal or passivated 316 Stainless Steel body. For applications in harsh environments it is recommended that the Acetal body material be specified.

2.5.3 Cable Options (inc. Detachable Cables)

A standard sensor is supplied with a fixed moulded cable entry. An optional detachable cable is available. Both cables have a 7 pin Hirschman connector at the end of the cable opposite to the sensor.

As an option, your sensor can be ordered with a detachable cable. Detachable cables are available in a range of standard lengths and are interchangeable amongst the range of Greenspan sensors. This option can provide benefits and cost savings.

Please refer to the [Engineering Note](#) in the appendix section of the manual for detailed instructions on connecting and disconnecting the detachable cable.

2.5.4 Communication Cables

A communication cable is required to connect the sensor to a PC. The standard cable (5CC-700) has a 7 socket Hirschman connector on one end and a DB 9 on the other end.

2.5.5 Optional Serial Output – SDI Adapter Unit

The EC3000 provides on-board data Logging of all data and serial output via RS232 to a Laptop or PC using the supplied SMARTCOM software. A feature of the sensor is the ability to also provide serial output in SDI12 format using a small SDI Adapter unit connected to the end of the sensor cable. The SDI12 Adapter unit (Part No 7SDI-1000) provides a standard 3 wire SDI12 output for connection to a third party Data Logger or Process Controller. The EC3000 Sensor can simultaneously provide on board data logging, as well as act as a standard SDI12 sensor.

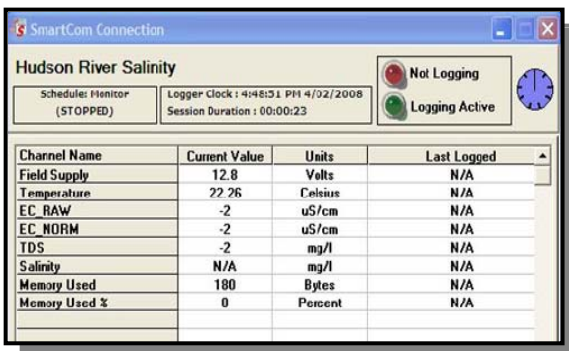

The screenshot shows the SmartCom Connection software window. The title bar reads "SmartCom Connection". The main window title is "Hudson River Salinity". There are two status indicators: "Not Logging" (red) and "Logging Active" (green). A clock shows the time as 4:48:51 PM on 4/02/2008, and the session duration is 00:00:23. Below this is a table with the following data:

Channel Name	Current Value	Units	Last Logged
Field Supply	12.8	Volts	N/A
Temperature	22.26	Celsius	N/A
EC_RAW	-2	uS/cm	N/A
EC_NORM	-2	uS/cm	N/A
TDS	-2	mg/l	N/A
Salinity	N/A	mg/l	N/A
Memory Used	180	Bytes	N/A
Memory Used %	0	Percent	N/A

When data is requested via SDI-12, the sensor will wake up and take a new set of readings for all data channels that are enabled. The sensor will then go into a low power, sleep mode. The user can enable or disable channels using SmartCom ([See Section 3.2.4](#)). The easiest way to confirm which channels are enabled is to view the SmartCom monitor (see example on right). Note - Memory Used and Memory Used % is not returned via SDI-12.

The data is returned in the same order as what is displayed in the SmartCom monitor screen.

Quick Set Up

Sensor

- Select data channels required using SmartCom ([See Section 3.2.4](#)).

7SDI-1000 (Refer to SDI-1000 User Manual)

- Set model type
- Set data channel output order if required
- Set data precision if required

2.5.6 On Board Battery Housing

The Greenspan range of logging Sensors including the EC3000 Sensors may be factory fitted with a non-rechargeable long life battery pack. This enables the sensor to be deployed at remote sites completely independent of above surface power supplies, (no cable connection) and allows for discreet applications. It also functions as a backup power supply in the event of a surface disturbance to the main supply.

The unit is designed to allow easy access to the battery compartments for battery changeover and is housed in a cylindrical body of approximately the same dimensions as the sensor housing, thus doubling the length of the sensor.



2.6 Battery Replacement

Batteries are removed by unscrewing the housing cover, as indicated below and gently levering the battery cells until they slip out. Replacement batteries must be inserted correctly or damage to batteries may occur. Align the +ve on the battery cells with the red indicator on the housing and push batteries in. Batteries are subject to leakage after depletion. The leakage is Thionyl Chloride, a toxic, corrosive non-flammable liquid that can cause damage to equipment and personal injury if in contact with the skin or eyes. Please replace batteries when depleted.

When installing replacement batteries within the battery housing it is necessary to push firmly on the cover until it clicks home over the O rings, after this it can be easily tightened on the thread by hand.

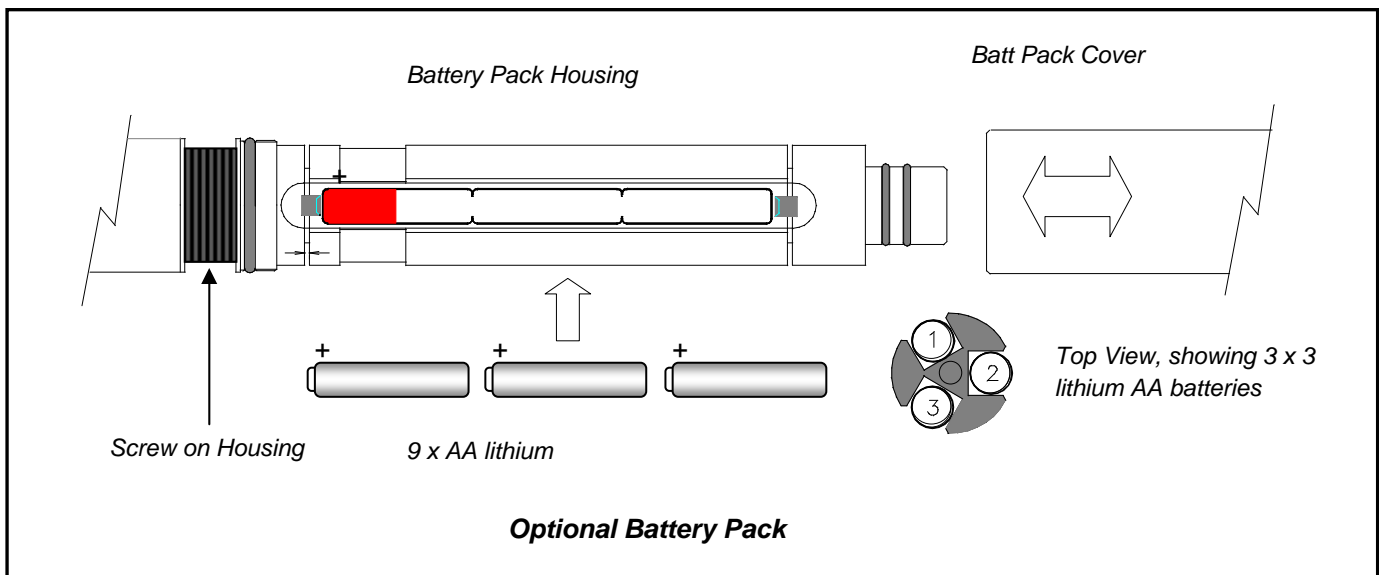

2.6.1 Important Battery Information

The type of battery used in the battery pack is Li/MnO₂, Lithium Thionyl Chloride 3.6V AA cells. A total of nine batteries are required for each sensor battery pack. This configuration supplies a maximum 10.8 volts at 5.2A/Hr and a useful field life, depending on sensor type and logging frequency, of up to 12 months.

REPLACEMENT BATTERIES ARE AVAILABLE FROM GREENSPAN ANALYTICAL

Standard AA lithium batteries (Duracell or Energiser Type) are NOT suitable for use in the sensor.

2.6.2 Battery Warnings:

- Do not dispose of batteries in fire, dispose of in appropriate manner.
- Do not short circuit
- Do not expose to water
- Do not crush or puncture
- Do not charge
- Do not over-discharge

To maintain the maximum possible life of the cells before replacement it is strongly recommended that an external power supply is connected to the sensor when downloading data. The power drawn when downloading is at its greatest level, therefore battery depletion will be much more rapid.

Battery life will depend on the battery type as well as the frequency of logging. Connection to a computer will drain the battery supply more quickly due to the higher current imposed by the RS232 serial data communications and will considerably reduce battery life. An additional internal lithium battery maintains logger data at all times but does not sustain the logging state. This battery is not user accessible and will maintain data for up to 10 years.

If the Sensor is fitted with on-board internal battery pack option and is to be placed in storage it is recommended that the logger be powered down and lithium batteries in the battery pack be removed. To turn off the logger after exiting from SmartCom, disconnect the communications cable and unscrew the battery cover. This exposes the battery compartment to allow removal of the batteries. Removing power will not affect any data remaining in storage so sensors could be downloaded away from the site if required.

2.7 Sensor Factory Calibration

- The toroidal head is assembled and encapsulated with epoxy resin to completely seal against any water ingress and provide physical rigidity and protection.
- The head is mated to the electronic circuit boards ready for calibration.
- The EC probe is placed in an environmental chamber and subjected to a matrix of temperature and EC inputs. A typical calibration collects data for each individual sensor at 11 EC inputs (0, 10, 20, 30, 40, 50, 60, 70, 80, 90 and 100 %FS) at 6 temperatures (0, 10, 20, 30, 40 and 50 deg C).
- A unique calibration curve, for the head and electronics set, is calculated from this data and loaded into the sensor.
- The sensor is then re-run through the environmental chamber to ensure that the calibration curve is correct over the entire working range and the sensor meets specifications.
- An extensive range of final calibration and inspection tests, including tests in solutions of known EC values, are carried out on every sensor.
- The sensor is visually inspected and packed ready for despatch.
- The complete calibration records, sensor history and batch number are placed on file and archived.

New EC sensors are supplied with a resistor calibrator. This conveniently allows a quick repeatable check of EC without requiring standard solutions. This quick reference check is detailed in [Section 3.3.1](#)

If a field calibration is to be carried out using solutions – it is recommended that laboratory standard solutions be used. An accurate temperature bath or thermometer will also be required to ensure accurate temperature readings of the solutions are obtained during the calibration process.

3 Sensor Operation

3.1 Wiring & Connections

The EC3000 is designed as a self-contained data logging sensor. It is normally powered by a 12-24V DC power supply – which can be battery, solar or Mains Plug Pack. The Logger has a large memory capacity and can operate for long periods between field visits. Typically the logged data is collected via laptop using the supplied SmartCom Software.

The following diagram illustrates the typical wiring arrangement for the EC3000.

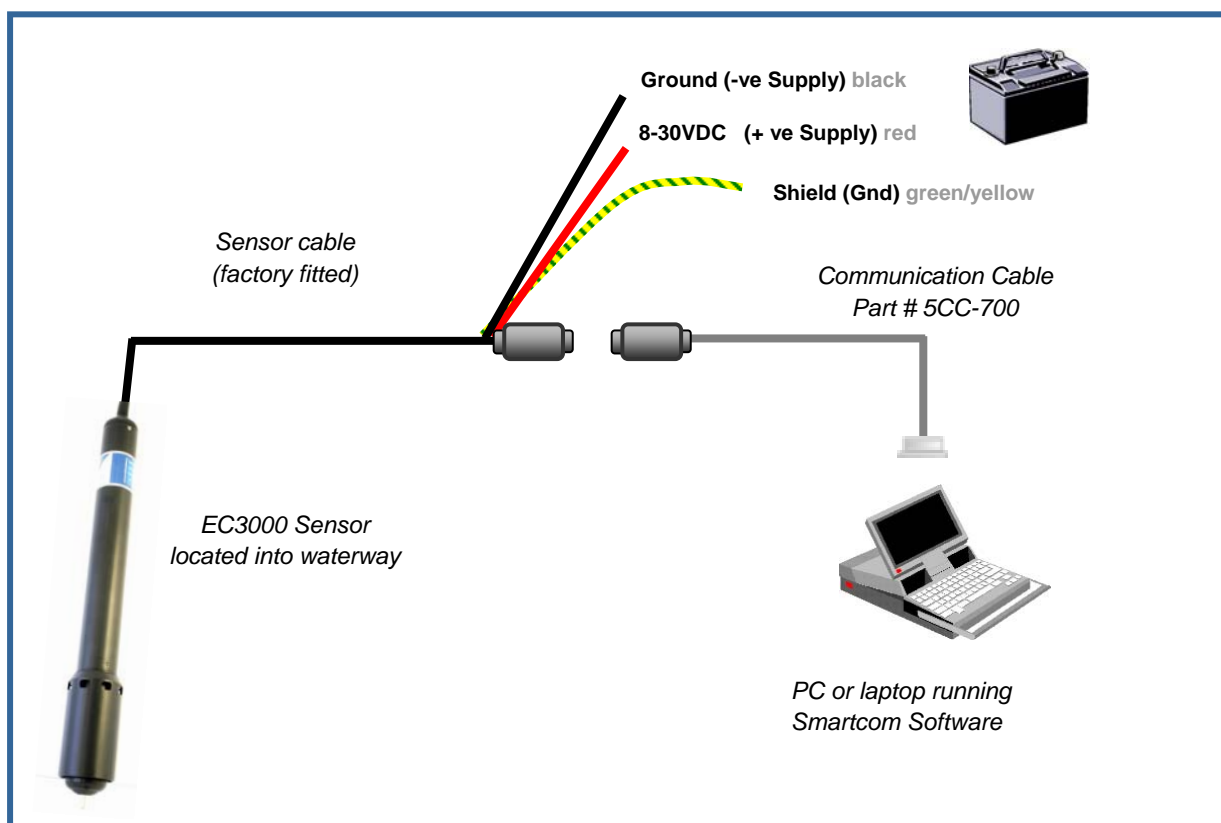

The SmartCom software provides for configuration of the data logger, collection of logged data, and all other functions. The Greenspan Aquagraph software provides graphical and tabular presentation of logged data and export to spreadsheet format. A brief description of the key components of the SmartCom software is included in this manual. A fully documented online help function is also included within the SmartCom software. It can be started by Hitting F1 key.

Alternatively the EC3000 Sensor can be used as an SDI12 Sensor using the optional Greenspan SDI12 Adaptor.

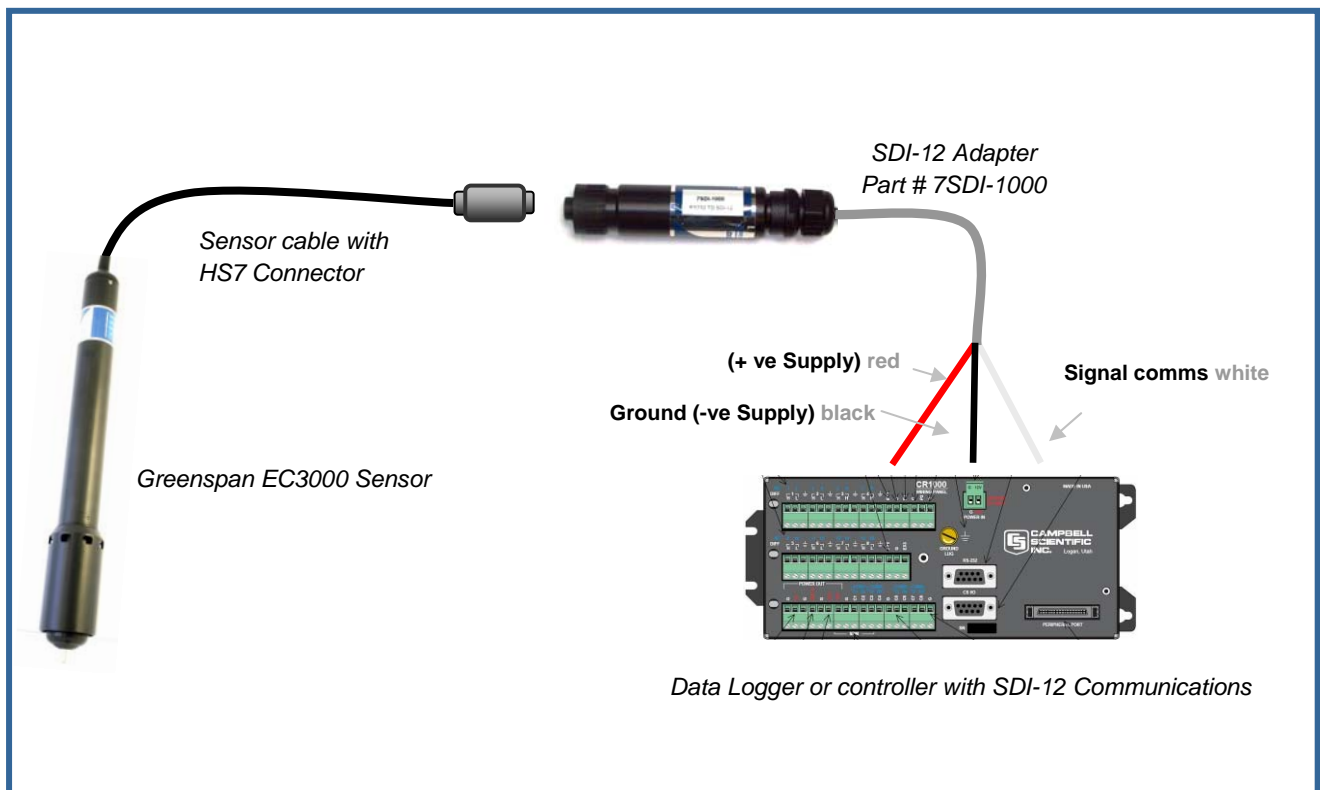

Typically the sensor will be connected to a Data Logger or Process Controller which will provide the power and ground connections and provide connections for serial SDI12 output.

The Power requirements of the sensor are detailed in the Specifications Brochure.

The sensor can support internal Data logging and operate as an SDI12 sensor concurrently.

This provides a benefit of having redundant Data Logging capability (internal) while also having the advantage of serial output to a third party Data Logger or Controller that may be connected via some type of telemetry or communications system.

The configuration and operation instructions of the SDI12 Adaptor unit are included in Appendix A.

3.2 Software Setup

Communication with the Greenspan logging Sensors is performed through the PC's RS232 serial port using the supplied software: **SmartCom for Windows**. The software supports older style 9 Pin Serial Ports (Com1 & Com2) as well as newer style USB serial Ports. If using a USB port – a USB to Serial 9 pin adaptor must also be used.

To Load the Software, Place Software CD in drive, and follow all prompts.

SmartCom for Windows includes two main components:

3.2.1 Direct Link

This program is a simpler version of SmartCom which bypasses the Location Explorer Interface to provide connection to a sensor. It is suitable for Direct Com Port Connections only. To connect to a sensor, select the Com Port and click the connect button. Once connected to the sensor the user has the full range of SmartCom functionality available to them but no local Database records of changed or existing Sensor Properties are stored by the software. This version of the Software is recommended for the casual field visit or for technical staff examining the sensor.

3.2.2 SmartCom

This is the full version of SmartCom which includes the **Location Explorer** Interface to provide management of individual and/or multiple sensors. This version of the software is the recommended version for customers wanting management of sensor(s) and their logged data.

The following software is required for running the EC3000 Sensor:

1. **SMARTCOM** for Windows runs on a PC, and facilitates manipulation of system setup information, processing and data retrieval. The program is supplied on a CD disk along with support files. It is compatible with WIN98, WIN2000, NT and XP operating systems. Mouse and keyboard operation is fully supported.
2. **Internal firmware**. The logger has a resident program that manages communications, data logging and data retrieval. It is not normally accessible by the user; however it may be upgraded in the field if required.
3. A utility program called **AQUAGRAPH** is also provided on the installation CD. This allows the user to view, graph and export the data. AQUAGRAPH may be accessed from within SMARTCOM. Online help is available from within the program.

The Software will load programs and other files into the following folders:

C:\Program Files\SmartCom for windows\

Several programs will be loaded

SmartCom

Smartpoll

Smart Standby

Another folder will also be created

C:\Program Files\SmartCom for windows\AquaGraph\

With the Graphical display program

Aquagraph

Note: Administrator Access is required for the Loading of SmartCom Program

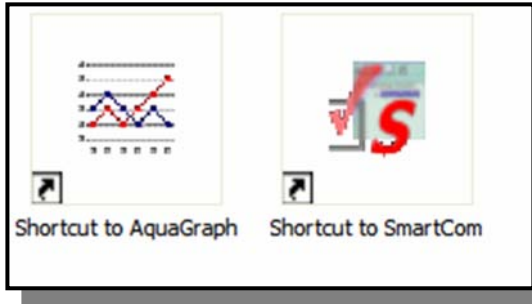

It is recommended that shortcuts be created for the 2 main programs SmartCom & Aquagraph and moved into a dedicated folder on the desktop.

To Run the Program double click on the SmartCom icon.

To use the full functions of the software a fully operational sensor with power supply and all communications leads should be available. Either internal or external battery can be used to power the sensor.

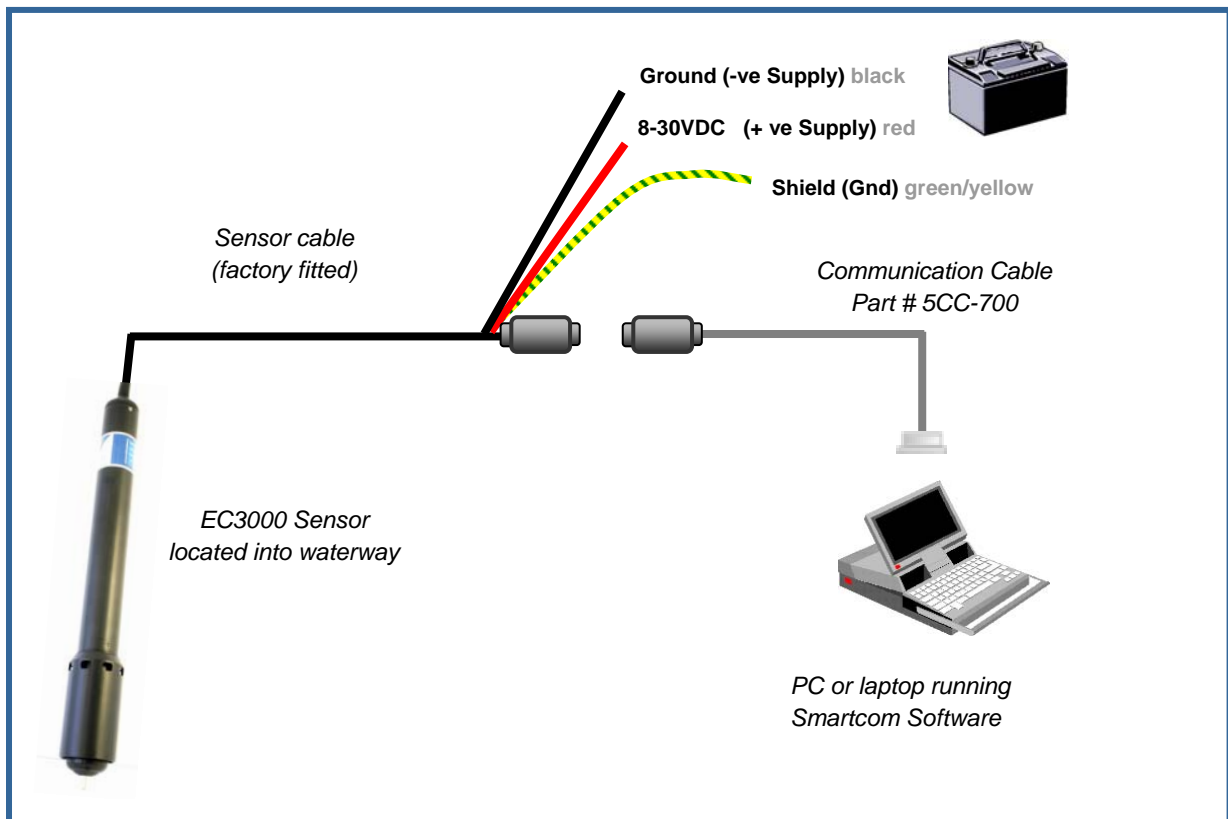

Fully Documented Help Function is available for SmartCom by hitting F1 key while software is running.

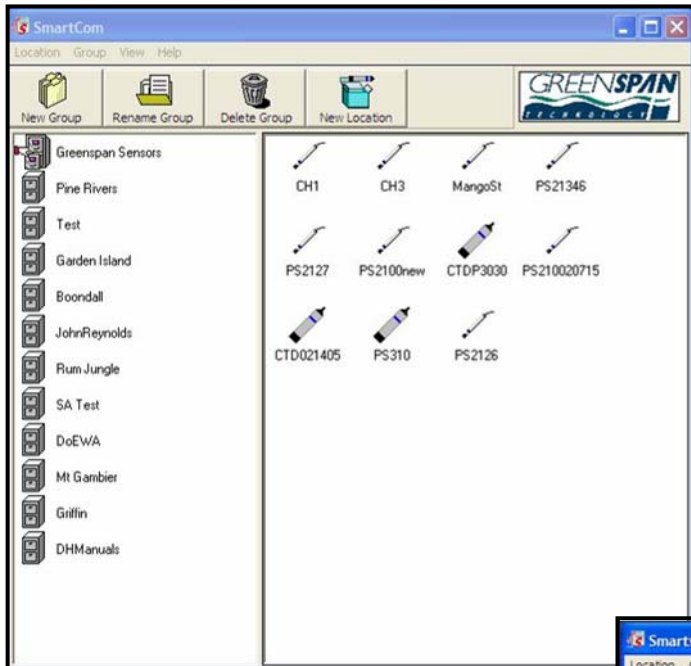

The Main Screen is divided into 2 Panels. The left side shows the Groups. The right side shows the locations within each Group. (The concept allows all sensor sites to be put together into logical groups – eg by catchment, area, client, sensor type etc)

Locations refer to individual sensors that may be located locally or remotely. Groups and Locations should be named to reflect the actual station details.

The 4 buttons at the top allow the creation and removal of Groups, and Locations.

To create a new Group – Hit the New Group Button and fill in the preferred name.

To create a new location – highlight the Group then hit the New Location Button.

A wizard will start up to guide you through the process:

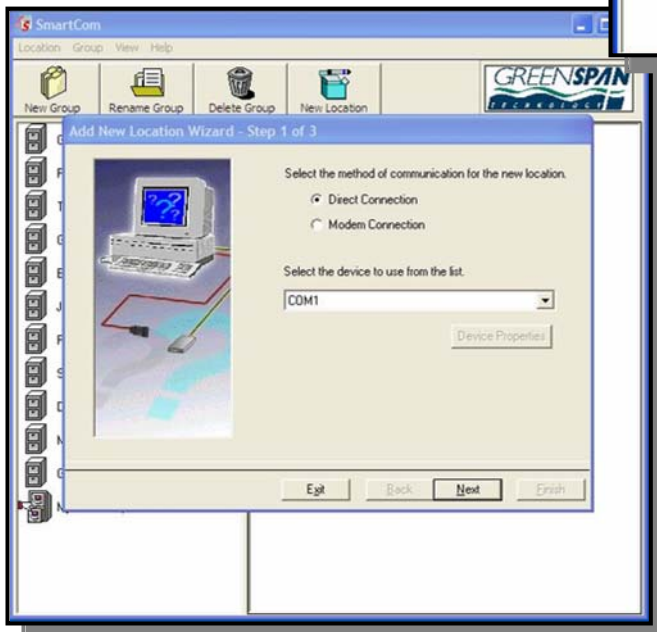
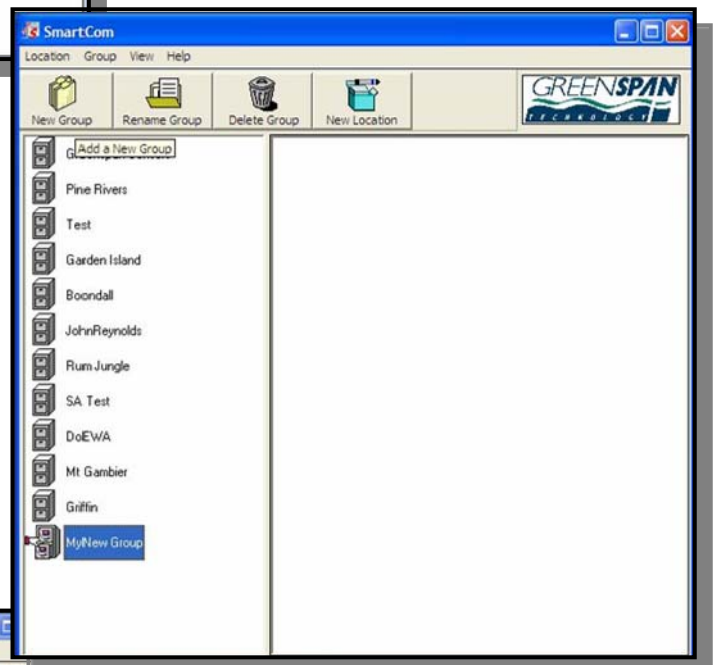

The Wizard Has 3 Steps:

Page 1 – requests how to connect to Sensor:

E.g. Direct Connection via Com port (Serial cable between Sensor and PC) Or

Modem connection via GSM / 3G / landline Modem. You will need to enter the phone number of the remote modem.

Hit Next Button.

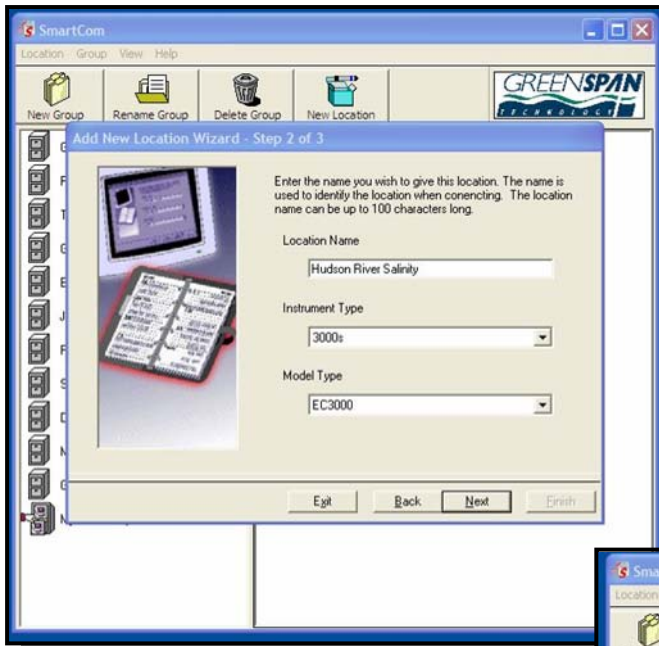

Step 2 requests Site Details:

Location Name
Instrument Type
Model Type

E.g. this screen will add a new site
With an EC3000 Logging Sensor
Named: Hudson River Salinity

Hit Next Button.

Step 3 Gives a Summary of the entered Data and asks for confirmation.

Change Details or

Hit Finish Button

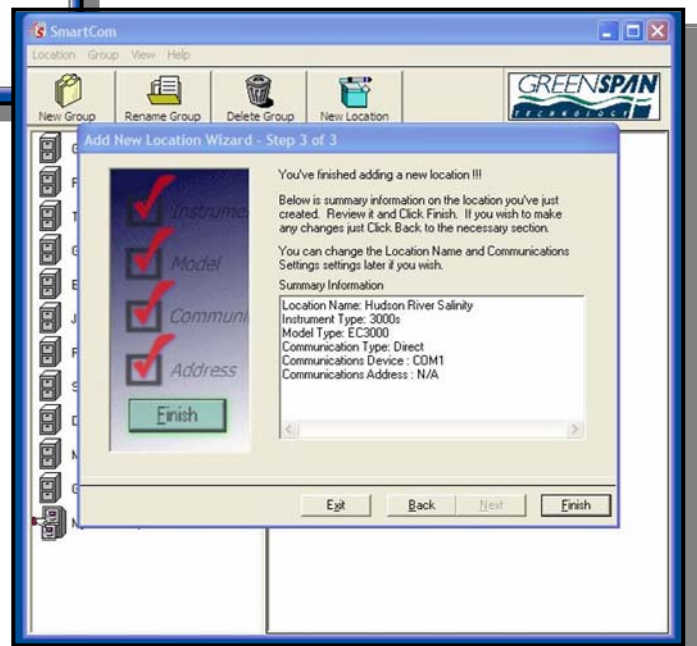

The screen then reverts to the original start screen and should now show the new Group and the new location.

To connect to the Sensor

Select the Group

Highlight the location and Hit Connect

Or

Double click on the location

All information relating to the Site is held in files created in the Smartcom folder directory.

**C:\Program Files\SmartCom for windows\...
...\Group Name\Location Name.**



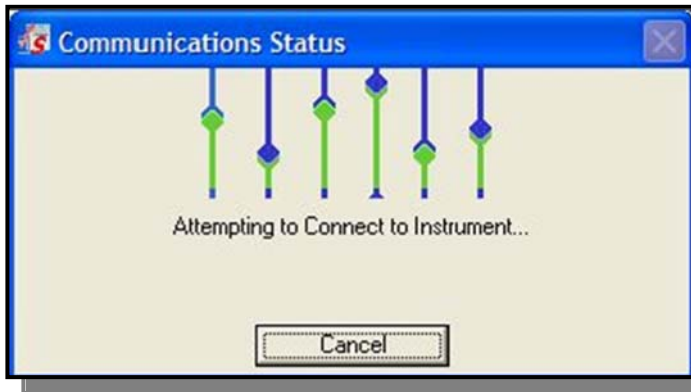

A Pop up will show the steps involved in communicating with the Sensor

- Attempting Wake Up
- Attempting to Connect
- Reading Details
- etc

This will take approx 30 seconds.

If connection cannot be established – check all power and communication connections.

When connection is established the Monitor Screen will appear...

This screen updates every 10 seconds and shows the real time data.

Clock times, Battery Volts, Logging Schedules Memory Usage should be noted. The Green or Red Leds indicate if Sensor is actively Logging or Not.

There are 2 tabs at the bottom. Hit the Logger Control Tab for all configurations and Logger set up details.

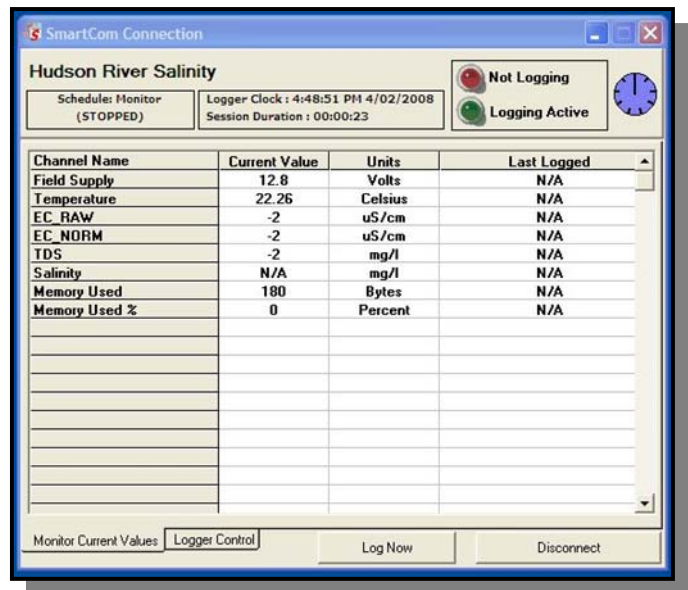

The Logger Control Screen provides access to all configuration, Data retrieval, Logger management and Calibration routines.

The Logger is very flexible and care must be taken to check that Data Logging has been initiated and is working properly, prior to deploying the sensor into a remote site. It is recommended that thorough testing of the sensor be performed in the office to provide confidence and experience with the various logger functions.

All Sensors are supplied from the factory fully calibrated and tested. It is not normally required to perform any additional calibration functions on the sensor.

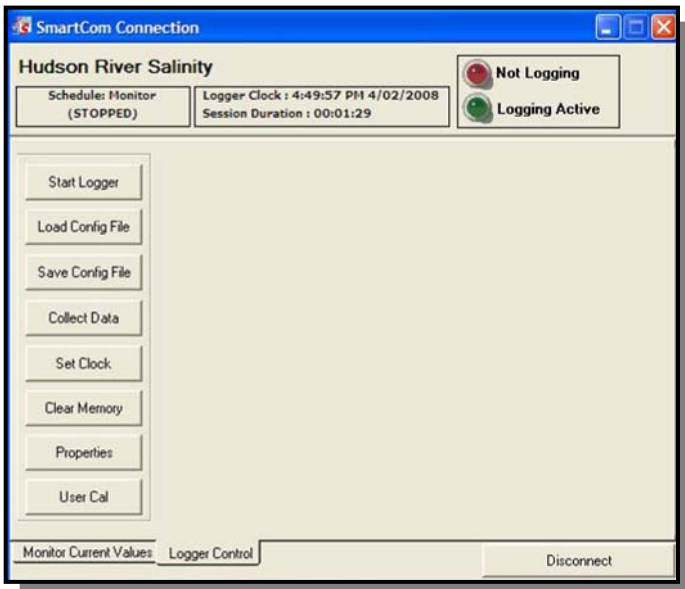

3.2.3 Properties

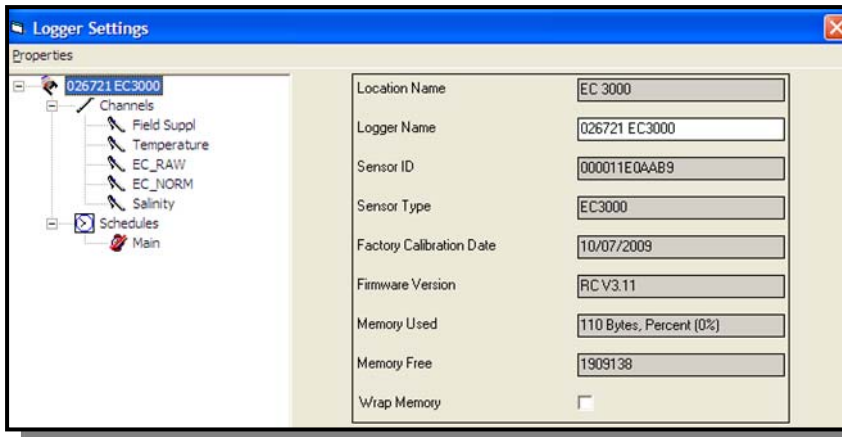

Key functionality of each of the Property Buttons will be described below.

This front screen provides a summary of all the key sensor information including Serial Numbers, Model Types Firmware Versions etc.

The Channels that are configured for the Sensor.

The Schedules control which channels are logged and the frequency of Logging.

The Schedules control which

3.2.4 Channels

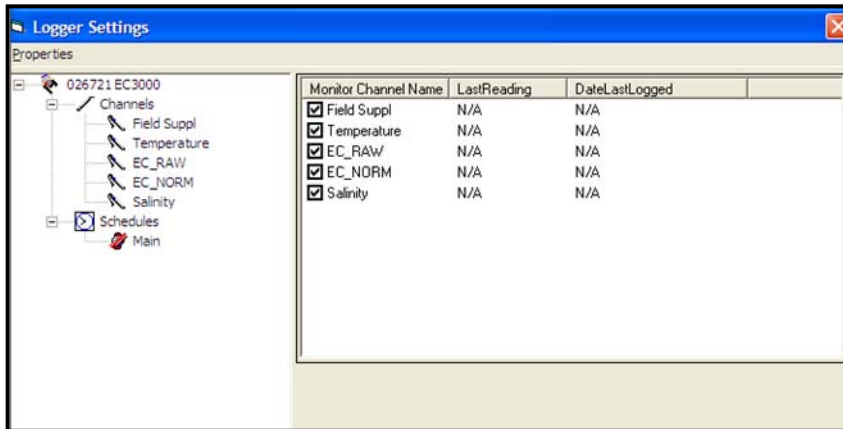

Controls and displays the various Channels that will be displayed on the Monitor Screen.

Channels that are not being used or not required to be displayed can be un checked and will not be displayed on the Monitor Screen.

(This screen below shows that Internal Battery (Battery Pack) is not used and will not be displayed on the Monitor Screen)

(This screen below shows

3.2.5 External Battery: (Solar Battery)

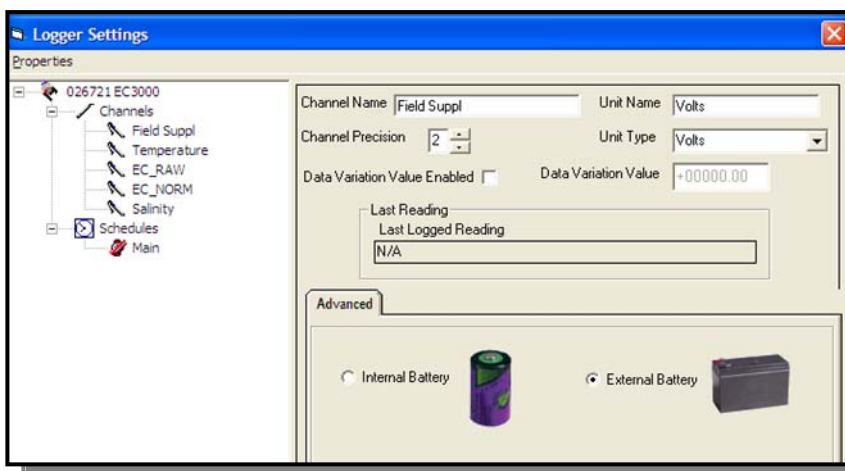

The Sensor will be powered by some type of DC (12-24V) power supply which may be either an internal battery pack or an external battery system. The user must click and select the correct battery type to ensure accurate battery life & voltage calculations.

Select the Option External Battery if using an external 12V battery.

3.2.6 Internal Battery: (Battery Pack)

Greenspan Sensors can be configured with an on-board lithium battery pack to provide a complete stand-alone logging sensor.

If the sensor is fitted with the internal on board battery pack select the Option at left: Internal Battery.

All batteries whether internal or external (sealed or acid type) will gradually degrade over time. The shelf life of batteries is generally 1-5 years, but can be affected by extreme temperatures.

A feature of the logger allows the user to enter the date of installation and expected Date of Renewal of the batteries, to ensure they are replaced before their due date.

Memory Calculator

3.2.7 Battery Life &

Provides an estimate of the Memory life and Battery life (days) based on the amount of logging that has been specified via the schedules.

The calculator uses information on the sensor power usage, the frequency of data logging, and the battery capacity to determine how long it will operate before the memory fills, or the batteries go flat.

If using a wrap memory function – the logger will fill with data and commence to overwrite the earliest data.

If using a solar power supply – the battery will likely last until its shelf life determines that it be replaced.

The user can enter the size of the Memory (bytes) & Battery (Ah), and add other power usage such as a Data Modem

Hit the refresh button to generate new estimates – after changing any of the

other parameters. A text box also pops up to provide key information to the user to advise of battery and memory information.

3.2.8 Temperature

The screenshot shows a configuration window for a Temperature channel. It includes the following fields and controls:

- Channel Name: Temperature
- Unit Name: Celsius
- Channel Precision: 2 (with up/down arrows)
- Unit Type: Celsius (dropdown menu)
- Data Variation Value Enabled:
- Data Variation Value: +000000.00
- Last Reading: (empty text box)
- Last Logged Reading: N/A

User configurable items include:

- Unit Name
- Unit Type
- Precision (No of decimals)

Data Variation can be ticked, and a value entered, which allows event based logging – should the amount vary by more than the variation between Scan periods.

3.2.9 EC Raw

The screenshot shows a configuration window for an EC Raw channel. It includes the following fields and controls:

- Channel Name: EC_RAW
- Unit Name: uS/cm
- Channel Precision: 0 (with up/down arrows)
- Unit Type: uS/cm (dropdown menu)
- Data Variation Value Enabled:
- Data Variation Value: +0000000.0
- Last Reading: (empty text box)
- Last Logged Reading: N/A

User configurable items include:

- Unit Name
- Unit Type
- Precision (No of decimals)

Data Variation can be ticked, and a value entered, which allows event based logging – should the amount vary by more than the variation between Scan periods.

3.2.10 EC Norm

The screenshot shows a configuration window for an EC Norm channel. It includes the following fields and controls:

- Channel Name: EC_NORM
- Unit Name: uS/cm
- Channel Precision: 0 (with up/down arrows)
- Unit Type: uS/cm (dropdown menu)
- Data Variation Value Enabled:
- Data Variation Value: +0000000.0
- Last Reading: (empty text box)
- Last Logged Reading: N/A

User configurable items include:

- Unit Name
- Unit Type
- Precision (No of decimals)

Data Variation can be ticked, and a value entered, which allows event based logging – should the amount vary by more than the variation between Scan periods.

3.2.11 Salinity

User configurable items include:

- Unit Name
- Unit Type
- Precision (No of decimals)

Data Variation can be ticked, and a value entered, which allows event based logging – should the amount vary by more than the variation between Scan periods.

The EC 3000 sensor calculates a salinity value, based on method “2530-D, Algorithm of Practical Salinity” (Standard Methods for the Analysis of Water and Wastewater). This method is also contained in “UNESCO Technical papers in marine science 44 – Algorithms for computation of fundamental properties of seawater.”

Note – All Channels are hard coded into the EC3000 Sensor – but can be individually configured to be included or excluded in Logging Schedules.

3.2.12 Schedules

ScheduleName	Start Method	Stop Method	Scans Completed
Main	1/01/2002	Def. STOP Date...	0
Hourly	1/01/2002	Def. STOP Date...	0

Schedules are user configured:

- Added
- Removed
- Modified
- Enable
- Disabled

Up to 4 Schedules can be running together.

Volts (Solar)

Example Schedule – Battery

This Schedule shows that Solar Battery (External Battery) volts will be measured (Scan Time) every 3 Hours. The Data will be logged (Record Time) every 3 Hours.

The Schedule is Enabled (box checked) and will operate whenever the Logger is turned on Logging.

The start an end time was set to Manual which means that this Schedule will start and stop with the logger.

Example Schedule – Water Quality Parameters

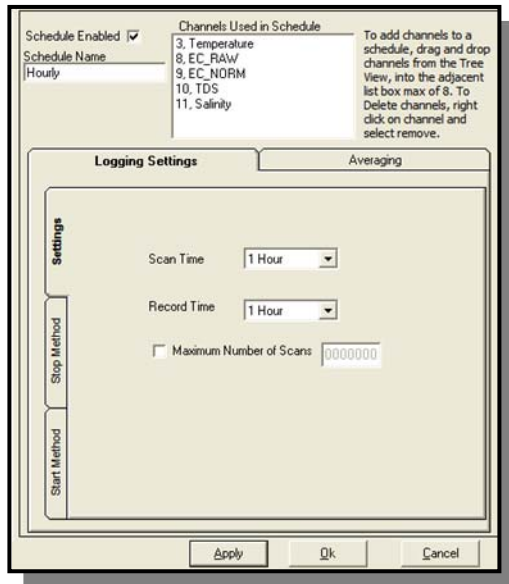

The Schedule controls the measurement and logging of data as follows:

When the logger wakes up to take measurements (Scan Time)

When the logger wakes up to Log Data (Record Time)

Maximum No of Scans (Optional – not recommended)

Which Channels are included into the Schedule (Min One, Maximum – all channels)

This example shows a Schedule that will wake up and measure Temp, EC Raw, EC Norm, TDS & Salinity – every 1 Hour.

It will also log the data for these channels every Hour.

Note – The Schedule Must be enabled (checkbox) for it to operate.

It is possible to have several Schedules in the list that are not enabled and hence will not run when logger is started.

3.2.13 Add New Schedule (Wizard)

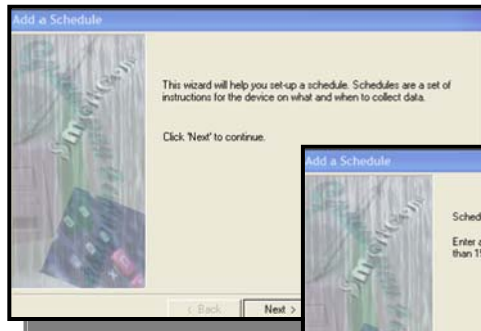

A wizard guides the user through the Add New Schedule procedure.

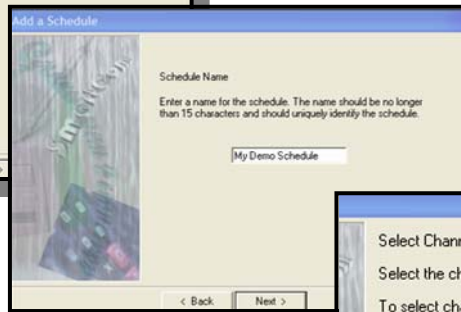

Give the New Schedule a Meaningful Name!
(e.g. 6 Hourly Temperature)

Highlight and Drag over the Channels that are required in the new schedule.
(This example shows Temperature Channel)

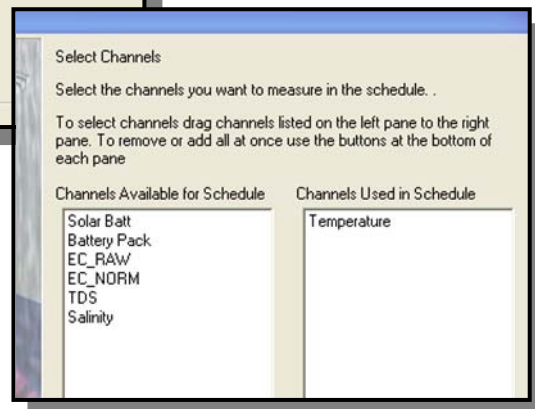

Select Logging Type
Select the type of measurement that the schedule will use

Set the Interval at which the device will scan and record data for the schedule

Scan Time

Record Time

Maximum # Scans

Averaging smoothes out logged values by averaging several readings for each log

Averaging Enabled

Number of Readings to Average (Must be > 0)

Interval between Readings (secs)

< Back Next > Cancel

Select the Scan and Record times from drop down list.

Sensor will wake up and take a measurement every Scan time, and check if the Data Variation is exceeded for the various Channels. If Data Variation has occurred – Data will be logged.

The unit will force a Data Log every Record time.

A limit can be placed on the Maximum scans. (schedule will stop after Max scans reached)

Averaging can be configured for the Schedule.

Select how you would like to start this schedule

Manual Start

Time

< Back Next >

Start and Stop times can be configured for the Schedule.

It is strongly recommended to use Manual start and stop (default) to ensure that all schedules are operational when logger is started.

Select how you would like the schedule to stop.

Manual Stop

Time

< Back Next >

3.2.14 Add New Schedule – Final Screen

The final Screen shows summary of the new Schedule.

The Schedule will now appear in the list of Schedules. One or more Channels must be added to the Schedule and it must be enabled to allow it to run.

This example shows that the Schedule named My Demo Schedule will measure and log Temperature Data every 3 hours, whenever the Schedule is enabled, and the logger is turned on. (Logging Active, Green LED on Monitor screen flashing).

3.2.15 Averaging

Averaging enables several readings to be taken and averaged, each time the sensor wakes up at the Scan Period. This allows data fluctuations to be smoothed. For example Logging of Tidal Water levels is typically averaged over say 10 readings say 3 seconds apart to remove the effects of Wind and Swell.

As averaging can increase the time required to generate a reading, warning will advise the limits of the averaging.

Note: Averaging does require the sensor to turn on more frequently at each Scan period and does have an impact on power usage and battery life.

Averaging can be configured for any or all channels.

3.2.16 Data Variation (Event Based Logging)

To provide Event Based logging the Sensor can be configured to Scan (take a measurement) on a frequent basis, but only Record Data (Log data) if a specific event size (Data Variation) has occurred since the last logged data point.

The Schedule must be enabled. The Channel must be in the schedule and configured with a valid Data Variation.

(This example shows EC will be logged if the reading varies by more than 100EC from the previous logged reading)

Note if the Data Variation is set to a very small amount, then it is more likely that the data variation will be exceeded, and data will be logged each Scan Time. Hence it is necessary to set the Data Variation based on realistic variations of the Parameter being monitored.

3.2.17 User Calibration Screens

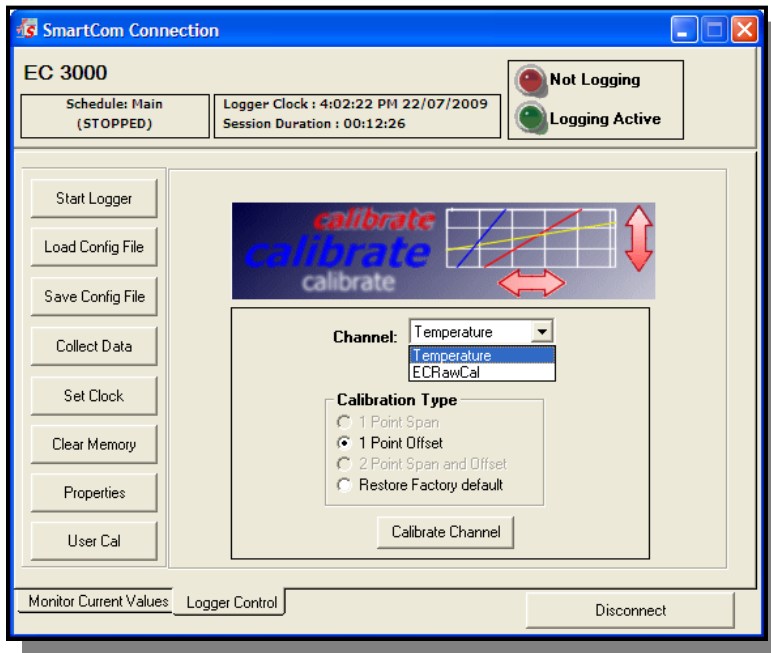

Allows re calibration of channels within the logger.

Please consult your sales or technical support specialist before recalibrating the sensor.

The Option “Restore Factory default” allows the sensor to be reset to the original factory calibration.

3.2.18 Clear Memory Tab

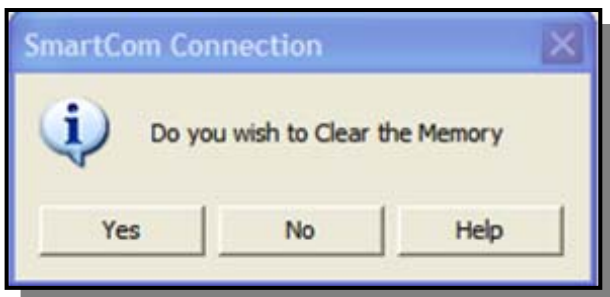

This control is used to clear the contents of the Data Logger Memory.

Once the memory is cleared – it is gone forever!!!

Only perform this function if you have collected and checked all the data from the sensor.

Aquagraph can be used to view and check data before deleting the memory contents.

If using the memory Wrap function – the memory will fill and then overwrite the oldest (earliest data)

If not using the Memory Wrap function – the memory will fill and then no more data will be logged. (I.e. all the data from the start of the logging period will be retained until it is cleared)

3.2.19 Set Clock

The logger has an internal clock to provide time stamping for all data logging. The clock can be reset to the correct local time via two different methods.

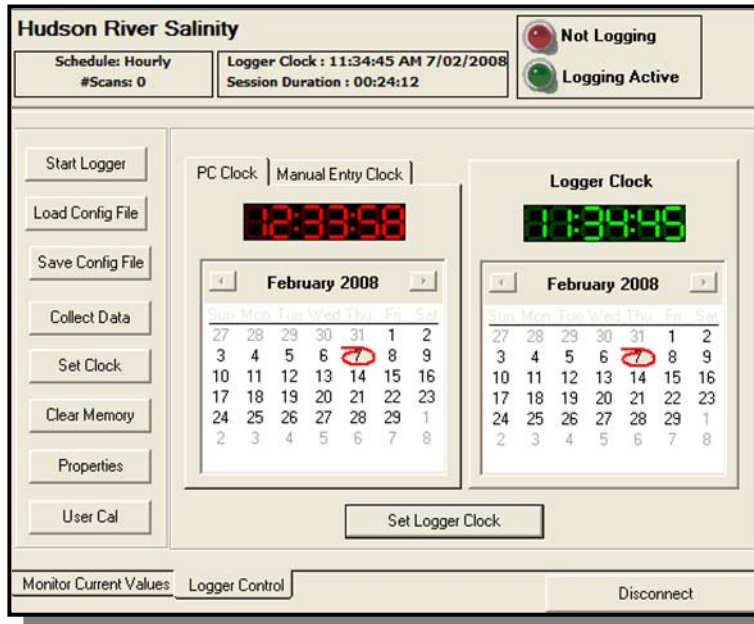

3.2.20 PC Clock

Option 1 – allows the Logger Clock to be set to the clock time of the PC being used.

PC Clock shown in red (left)
Logger Clock shown in green (right)

The Logger clock is displayed in the top of the screen – and should be checked to confirm it is correct.

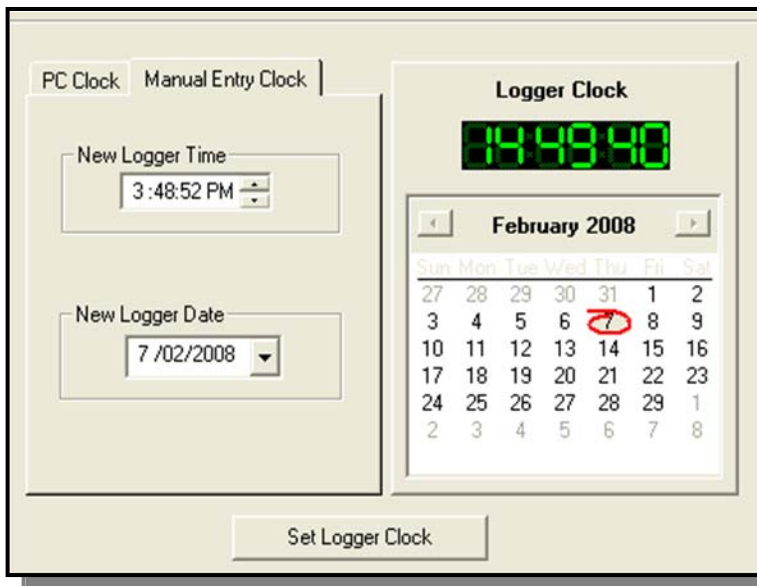

3.2.21 Manual Entry Clock

Option 2 – allows the Logger Clock to be set to a User Manually Entered time.

Screen shows the drop down menus for the user to enter the correct local time and date settings into the Logger Clock.

Logger Clock shown in green (right)

The Logger clock is displayed in the top of the screen – and should be checked to confirm it is correct.

3.2.23 Collect Data

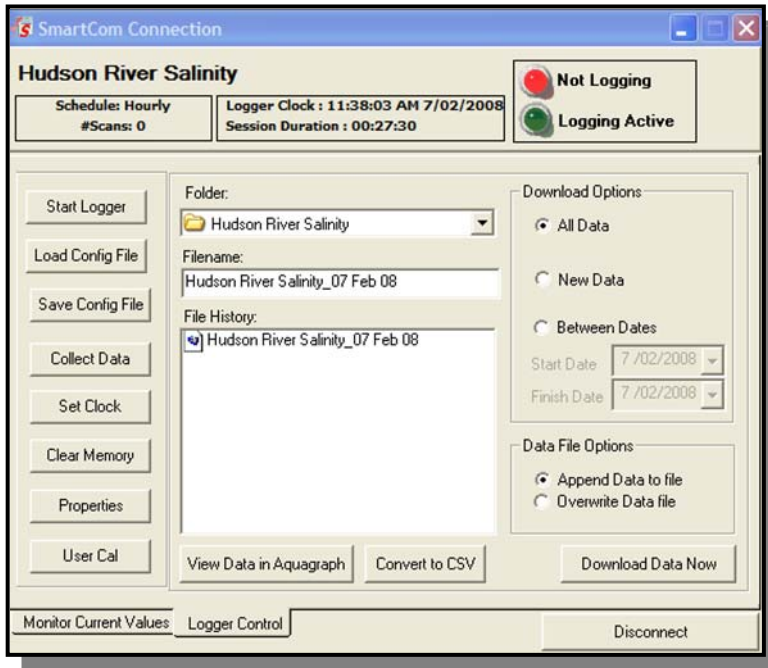

This allows collection of the logged data. Various options allow collection of all Data, New Data or Data between specific dates.

Data can be downloaded to new files, or appended to existing files.

Data is not deleted from the Logger during this process and can be re-collected many times.

The Data Logger does not need to be stopped for the collection process, and normal logging of data will continue while the data downloads.

The Data is extracted in Binary Format and requires the Aquagraph program to decode into text format.

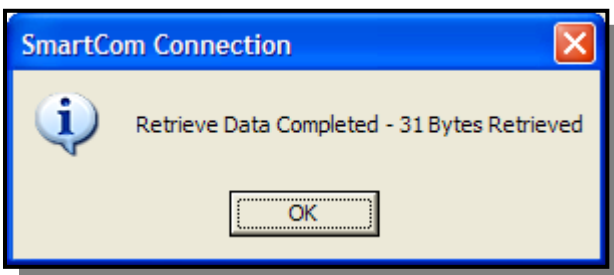

Data collection can take up to several minutes for direct connection (serial cable) or longer for remote modem connections.

It is always more efficient to perform regular data collections of New Data – and append to a Master File, rather than try to collect very large parcels of data.

Once complete the Data can be viewed in Tabular and Graphical format by hitting the View Data in Aquagraph button.

3.2.24 Aquagraph – Tabular View

Date	Time	Elapsed Time (mins)	Schedule	Parameters				
				Temperature Celsius	EC RAW uS/cm	EC NORM uS/cm	TDS TDS	Salinity mg/l
7/02/2008	1:40:00 PM	0.0000	1	22.12	-5046	-5304	15	
7/02/2008	1:45:00 PM	5.0000	1	22.13	-4339	-4559	15	
7/02/2008	1:50:00 PM	10.0000	1	22.13	-5761	-6054	15	
7/02/2008	1:55:00 PM	15.0000	1	22.14	-4340	-4560	15	
7/02/2008	2:00:00 PM	20.0000	1	22.14	-4340	-4560	15	
7/02/2008	2:05:00 PM	25.0000	1	22.14	-3629	-3812	15	
7/02/2008	2:10:00 PM	30.0000	1	22.13	-3626	-3811	15	
7/02/2008	2:15:00 PM	35.0000	1	22.14	-4339	-4559	15	
7/02/2008	2:20:00 PM	40.0000	1	22.21	-3642	-3822	15	
7/02/2008	2:25:00 PM	45.0000	1	22.22	-3644	-3823	15	
7/02/2008	2:30:00 PM	50.0000	1	22.22	-2934	-3077	15	
7/02/2008	2:35:00 PM	55.0000	1	22.21	-4355	-4569	15	
7/02/2008	2:40:00 PM	60.0000	1	22.21	-3643	-3822	15	
7/02/2008	2:45:00 PM	65.0000	1	22.21	-5066	-5315	15	

Shows all logged data from the sensor.

Data can be exported to excel spreadsheet.

To generate graph – highlight column(s) of interest and hit graph button.

3.2.25 Aquagraph – Graphical View

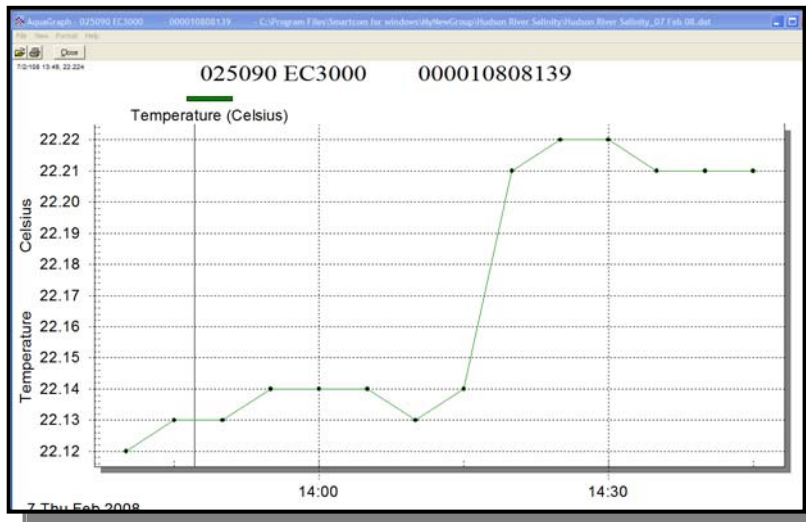

Graphs will self scale across the dates and ranges requested.

Multiple channels can be plotted on single graph, as well as stacked graphs for many parameters.

Various tools are available from Menu for highlighting points, adding text, zoom function etc.

Graph can be exported as a graphic (.bmp) file for reports etc.

& Options

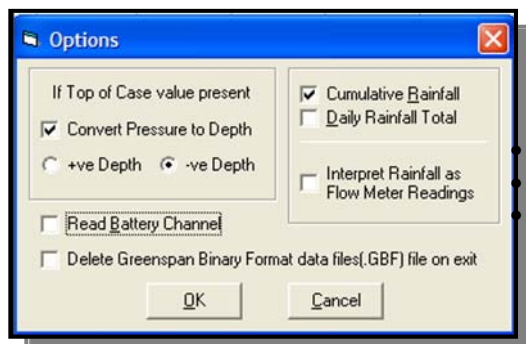

Battery Details can be included.

Rainfall can be included in various formats
Instant readings (each tip)
Cumulative Total
Daily Rainfall total

Other options support display of flow meter readings, and conversion of pressure/level to Depth of Water above or below specified Datum levels.

Fully documented Help Function is available for Aquagraph by hitting F1 key while software running.

3.3 Quick Check and Re-Calibration

The Factory supplied Calibration Certificate will provide detailed information on the calibration of the sensor and should be retained for future reference.

To maintain high quality control over monitoring programs, it is recommended EC calibration is checked at least every 3-6 months. If re-calibration is required a method is presented here using Greenspan EC Calibrators and using Standard Solutions. Alternatively sensors may be returned to an authorised Greenspan agent for re-calibration.

The following procedures detail a quick method to check the calibration for both full-scale and zero using the supplied loop calibrator CK-100.

Note: For new EC sensors each calibrator is clearly marked with a serial number and non-normalised calibration value.

3.3.1 Quick check

1. Remove the sensor from the water, unscrew the shroud and dry the EC head and temperature button.
2. Connect the sensor to a PC and run SmartCom.
3. Once connected the monitor screen will display the readings. The EC value should read Zero +/- 1% of the full scale range of the sensor.
4. Place the loop calibrator through the hole in the EC head and plug the connector together.
5. The non-normalised EC value should read the value marked on the loop calibrator +/- 1% of the full scale range of the sensor.
6. This confirms that the sensor electronics has remained stable and no further action should be required if the sensor is within +/- 1 % FS.

3.3.2 Re-Calibration using the loop calibrator

While the EC sensor is designed for long term stability it is normal for any electronics to experience some drift over time. If re-calibration is required -

1. Remove the shroud and ensure the sensor is clean and dry.
2. Provide power to the sensor, connect sensor to a PC with appropriate communication cable.
3. Run SmartCom for Windows.
4. In SmartCom for Windows, select User Cal from Logger Control menu.
5. Select the EC Channel.
6. Select 2 point Span and Offset Calibration Type.
7. The zero value is read in SmartCom **without** the loop calibrator. The screen should display a window to allow entry of the new low value, type in the new value to be read by the Smart Sensor for zero, eg: (0000.00) click OK.
8. Loop the EC calibrator wire through the EC head and connect together.
9. Enter the value marked on the loop calibrator, click OK.

3.3.3 Re-Calibration Method Using Calibration Solutions

The sensor can be checked by use of known laboratory conductivity standards, a thermometer and/or a third party EC sensor.

1. Ensure the sensor is clean and dry. Shroud should be fitted.
2. Provide power to the sensor, connect sensor to a PC with appropriate communication cable.
3. Run SmartCom for Windows.
4. In SmartCom for Windows, select User Cal from Logger Control menu.
5. Select the EC Channel.
6. Select 2 point Span and Offset Calibration Type.
7. The zero value is read in air. The screen should display a window to allow entry of the new low value, type in the new value to be read by the Sensor for zero, eg: (0000.00) click OK.
8. Submerge the sensor in full scale calibration standard. Sensor should be gently agitated to remove any air bubbles. Allow the temperature of the solution and sensor to stabilize (recommend at least 1 hour).
9. Enter the non-normalised EC value of the standard solution, click OK.

3.4 Installation

3.4.1 Field Deployment Considerations

The sensor head should always be completely submerged and positioned such that the possibility of air bubbles becoming entrapped within the sensor hole is minimised. Large bubbles may cause errors if trapped.

For applications in harsh environments it is recommended that the optional Acetal casing be specified.

The sensor head should be periodically inspected for fouling, and can be cleaned with fresh water and damp cloth. The protective shroud is easily unscrewed from the head for quick access. Bottle brushes are commonly used for cleaning the sensor hole. In marine environments crustaceans may need removal at regular intervals.

Please note that EC sensors fitted with the protection shroud are calibrated in the factory with the shroud on. If the shroud is removed the calibration in water will be affected significantly. This is not a problem if the shroud is removed in air when checking calibration with the EC Calibrator supplied. Please ensure that the shroud is always fitted for normal use in water and only removed while cleaning and checking in air.

The body should always be fully immersed under the water to ensure the electronic module is at water temperature and to avoid any possible anodic/cathodic action taking place on the stainless body due to the oxygen difference across the boundary.

Care should be taken if clamps are to be attached to the Stainless Steel body as the depletion of oxygen to the clamp/probe interface can cause corrosion due to anodic/cathodic action. It is recommended that Delrin body sensors be used if clamping.

Sensors should generally be installed such that they can be easily and safely removed for cleaning and servicing. For environmental applications the sensor can often be mounted inside a section of PVC or steel pipe which enters the water body. The sensor can then be slid down inside the pipe until the sensor head just protrudes into the water body. This provides a high degree of protection for the sensor from environmental (sunlight, heat, flood debris etc) as well as from other influences such as cattle, vandalism

etc. Most sediment transport occurs during storm events and flood conditions. Protection from floating debris damage is an important consideration along with adequate tethering of sensors.

Another widespread application of the sensors is to hang the sensors in the water body from a fixed structure or a floating buoy or pontoon. Generally in lakes or estuary applications the sensor can hang on its own cable, and easily retrieved for routine servicing.

3.4.2 Cabling Considerations

Care should be taken with installation and field servicing to ensure the cable is not subjected to persistent pulling snagging or severe compression. Cyclic loading of the cable should also be avoided through careful sensor deployment. Additional stilling wells or mounting brackets may be required to prevent sensor movement which may cause long term cable movement. Where cable runs are required which may be subject to environmental effects (heat, water movement, sunlight, flood debris etc) it is advisable to protect the sensor cable inside a slightly larger diameter conduit such as PVC, steel or polyethylene. This also allows the sensor cable to be pulled out – should a sensor change-over be required at the site. Maximum cable runs up to several hundred meters are possible without affecting electrical signals. The maximum cable length is dependant on the capability of the com port of the computer. Most computers should be capable of driving a 150 to 200m cable length.

3.4.3 Typical Sensor Installations

1. Edge of river/stream/lake embankment.
2. Side of boat/vessel.
3. Mounted within a stilling well off stream from main flow.
4. Mounted within drainage channels/pipes.
5. Suspended from dam walls or floating pontoon.
6. Sensor anchored to bed of lake/stream.

Field Installation must ensure:

- The sensor is anchored or held in position or located so it is not subject to any movement during normal operations.
- Sensor is protected from direct sunlight to avoid high temperature fluctuations
- Sensor is protected against high turbulence and possible debris loading during flow events

3.4.4 Other Considerations

Environmental compatibility should be checked before using the sensors and advice sought from Greenspan if any doubt exists. The sensor utilises some 316 stainless components that are suitable in a majority of situations but care should be taken against possible corrosion in high Chloride, Sulphate or Ferric solutions. The body should always be totally immersed under the water to ensure that the sensor is at water temperature and to also avoid any possible anodic/cathodic action taking place on the components at the water-air interface. If using clamps to mount the sensor – these should be of a type that evenly clamps the sensor body without excessive loading that could damage the sensor body.

3.4.5 Guidelines for cleaning equipment

The sensor may be cleaned using a soft cloth, mild detergents and warm water. Bottle brushes are commonly used for cleaning the sensor hole. If the sensor shows signs of marine growth a light biocide can be used to clean and kill any biological growth on the sensor.

4 Appendix A -Additional Information

4.1 Specifications

Measurement Technique	EC – Toroidal Conductivity Temp – Stainless Steel thermistor
Standard EC ranges available	0-1000µS/cm, 0-2000µS/cm, 0-5000µS/cm, 0-10000µS/cm, 0-20000µS/cm, 0-60000µS/cm, 0-70000µS/cm.
Other Ranges are available	Yes – calibration charge may apply –refer sales office
Sensor Outputs	Internal Data Logger – serial data via SmartCom software Optional adaptor provides SDI12 serial output (3 wire)
Overall Accuracy (combined linearity, hysteresis and repeatability)	EC +/- 1 % full scale range Temp +/- 0.2°C
Long Term Stability	0.2% full scale per annum
Resolution	EC – 1µS, Temp – 0.05°C
Normalisation	Normalised to 25°C
Cable Type	Polyurethane sheathed cable, OD 8m, with 3mm vent tube, moulded entry, HS7 connect
Cable Lengths	10, 20, 30, 50, 100, 150m (32, 65, 100, 165, 325, 490ft)
Power Supply	8 to 30Vdc (at sensor) , or on-board battery pack (optional)
Power ESD protection	2000 volts
Current consumption	Sleep <0.2mA, logging 50mA, communicating 30mA
Sensor warm up time	5 seconds
On-board battery pack (option)	Housing screws to sensor (OD x L) 47mm x 250mm
Battery capacity	9 x Lithium AA (3.6 Volt) – Total capacity 5.2Ah @ 10.8v
Typical field life (battery pack)	Over 6 months remote operation @ 1hr data logging
Internal data logger	Non-volatile, battery backed RAM with real time clock
Memory size	2Mb capacity, with user selectable wrap function
Measuring units	User definable
Data storage	250,000 readings (Typically 5 minute data for > 12 months)
Logging frequency	User selectable from 1 second up to once per day
Averaging alarms	User selectable via supplied SmartCom software
Operating temperature	0-50°C
Depth rating (water column)	100m
Storage Temperature	-5°C to +60°C
Weight	950g plus cable weight (665 per 10m length)
Dimensions (L x OD)	490.70mm x 47mm (19.32" x 1.85")
Wetted materials	UPVC, acetal, 316 passivated stainless steel, polyurethane, viton

4.2 Quick Start Guide – EC3000 Electrical Conductivity Sensor

Procedures for connecting and configuring the Greenspan EC3000 Sensor. Further details in the Sensor Manual included on the Greenspan CD.

You should have received:

- Certificate of Conformance Sheet
- CD Manuals & Software
- Greenspan EC3000 Sensor
- Cable Options per order

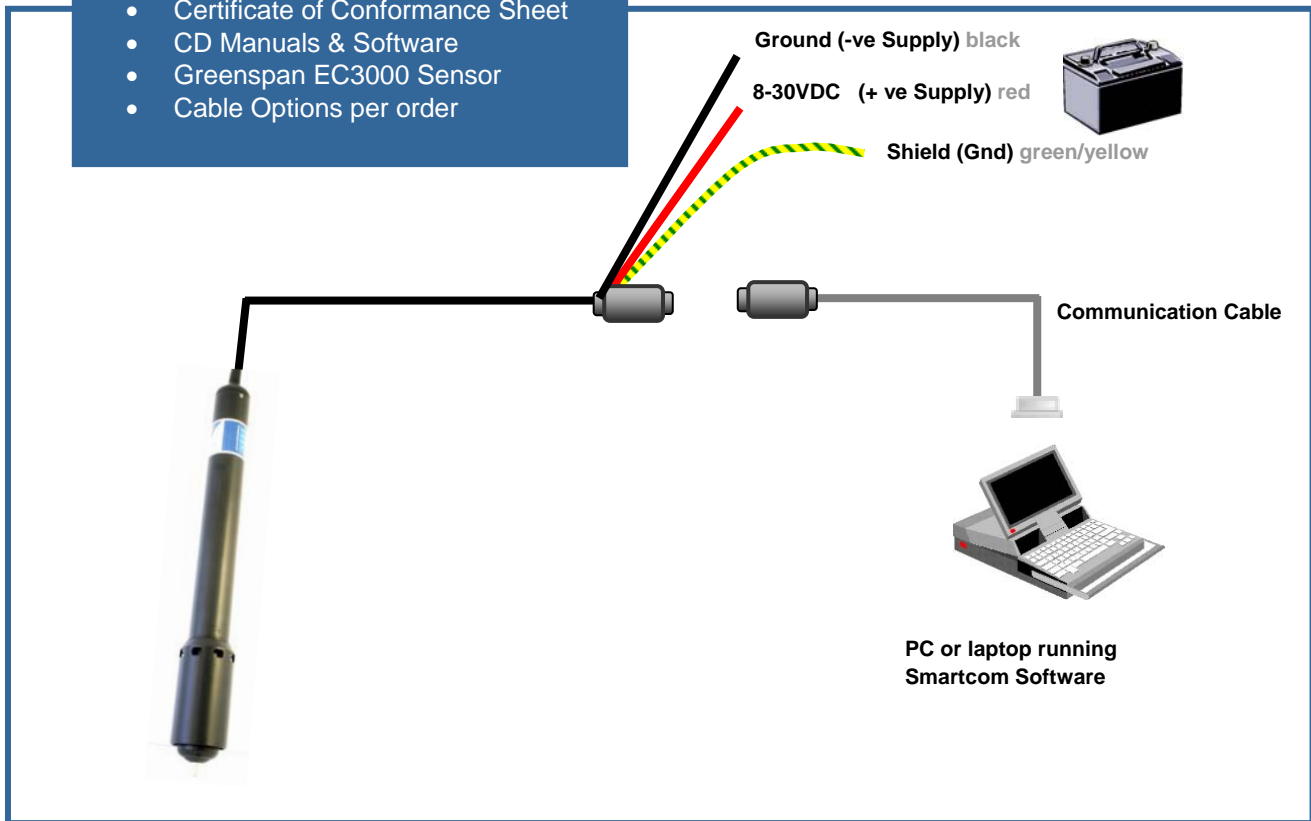

As an option the sensor may be configured with on board battery housing

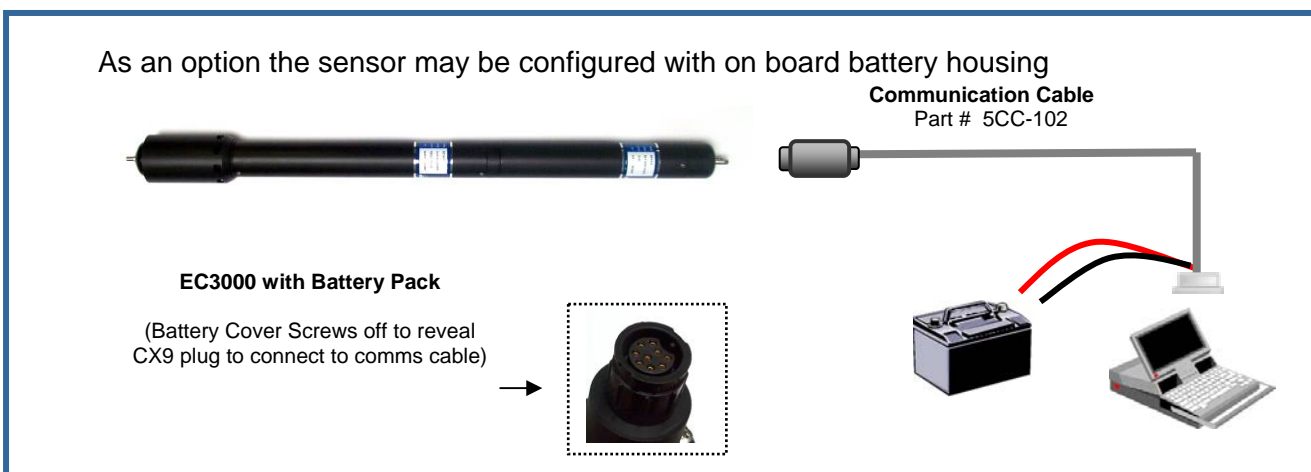

EC3000 provides a complete measurement & logging system for water conductivity and temperature. Communication and configuration of the sensor is via the Smartcom Software on the supplied CD.

4.3 Example – Certificate of Conformance



EC3000 Electrical Conductivity Sensor

CERTIFICATE of CONFORMANCE

Customer: "Click here & type Customer name"
Model No. EC3000 Electrical Conductivity Sensor (Tyco Environmental Systems material # 700-5100)
Sales Order Reference: "Click here & type SO Reference"
Serial Number: "Click here & type S/N"

Product Information



EC3000 Electrical Conductivity Sensor

Range	EC	0 – "Type Range here" μ S/cm
	Temp	0 – 50°C
Linearity & Accuracy	See Note 7	
Cable Length	"Click here & type Cable length" M	
Firmware Version	RC3.11	
Ext Supply Voltage	9 - 30 VDC	
Power	+ve	Red
	Gnd	Black
	Shield	Yellow/Green
Output	RS232	
Connection Code	HS7/Detachable/CX9 (delete applicable)	
For further connection detail please refer to the Connector Chart supplied.		

User Notes

- Do not attempt to dismantle the sensor as it will void the warranty. Contact your agent for technical advice.
- The sensor is protected against reverse polarity connection.
- The sensor is fitted with a lightning protector/surge device.
- The EC sensor is temperature normalised to 25°C over the range 0 - 30° C.
- The sensor is compensated for temperature induced errors over the range zero to 50° C.
- The sensor turn on time is factory set to 5 seconds.
- Linearity and Accuracy specifications are as follows:

EC	1% Accuracy	0.5% Linearity
Temperature	$\pm 0.2^\circ\text{C}$	
- Maximum submersible pressure is 100m

Inspected By: _____ 15 March, 2010

Manufactured By:
 Tyco Environmental Systems (Greenspan Analytical Plant)
 22 Palmerin Street
 WARWICK QLD 4370
 AUSTRALIA
 Phone: + 61 (0)7 46601888



4.4 Engineering Note – Detachable Cables

ENGINEERING NOTE

RELEASE DATE: 28/4/2008

SUBJECT: Connecting and Disconnecting the Detachable Cable for Greenspan Sensors (packaged in 47mm & 65mm Tubes)

IMPORTANT NOTE:

You have been supplied with:

2 x O-Rings (Greenspan part number 011-OR16X2.5)

2 x Grub Screws (Greenspan part number 512-M4X6SS316P)

1 x Allen Key

Prior to connecting your sensors to the detachable cable, please ensure that the detachable cable entry has been fitted with O-Rings supplied as detailed above. Ensure O-Ring grooves are greased and then slide O-Rings and fit into the recessed grooves.



Refer to the following instructions for **connecting** to your sensor to the detachable cable

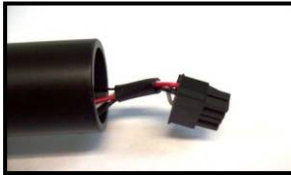

1. The sensor connector is exposed and ready to connect to the cable connector.

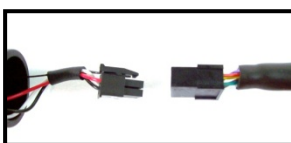

2. Align the cable connector with the sensor connector and push together. The connector is polarized and will only fit together one way.

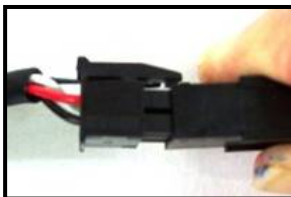

3. Once connectors are completely pushed together, the rocker arm on the sensor connector will clip in with the cable connector and secure the connection.



4. Carefully feed the connection back into the sensor tube taking caution not to crimp or damage any wiring. Ensure the O-Rings have been fitted to the moulded cable entry as directed at the beginning of this document



5. Twist carefully to align the grub screw holes. Firmly push the tube back onto the moulded cable entry



7. Screw in two (2) 512-M4X6SS316P grub screws to secure the cable and the sensor with supplied allen key



8. The cable is now securely fitted to the sensor.

Refer to the following instructions for **disconnecting** to your sensor to the detachable cable



1. Sensor with cable attached and ready for cable disconnection.



2. Remove the two (2) grub screws (Greenspan part #512-M4X6SS316P) using the Allen key supplied. (N.B allen key is supplied in spare parts kit with original packaging)

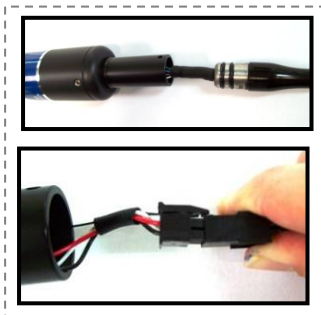

3. CAREFULLY pull tube away from cable mould. Once the tube has been pulled away from cable mould, the connector will be revealed as pictured left.

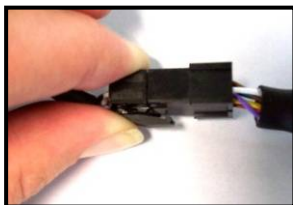

4. Release locking device on the connector by gently pinching rocker arm on the cable connector and pull apart.

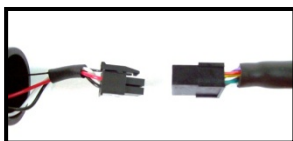

5. The sensor and cable are now detached.

Note: When the cable is not connected to a sensor, please ensure the supplied vent cap is fitted to the vent tube (if applicable)